

# Meath County Development Plan Phlean Forbartha Chontae na Mí 2013 - 2019

APPENDIX 15:

RURAL DESIGN GUIDE



comhairle chontae na mí  
meath county council







## MEATH RURAL HOUSE DESIGN GUIDE



comhairle chontae na mí  
meath county council

**Published By:**

**Meath County Council, December 2009**

**Authors:**

**Shay Scanlon, Shay Scanlon Architects.**

**Planning Dept., Meath County Council.**

All sketches and illustrations (unless otherwise noted) by Shay Scanlon Architects.

All photographs (unless otherwise noted) by Shay Scanlon Architects

Neither the Authors (Shay Scanlon, Shay Scanlon Architects and The Planning Dept., Meath County) nor the publishers (Meath County Council) are responsible for consequences or use or advice offered in this document by anyone to whom the document is supplied. Nor are they responsible for any errors, omissions or discrepancies in the information provided.

**Copyright © 2009 Meath County Council**

**Shay Scanlon Architects.**

All rights reserved. No part of this document may be reproduced in any form (including by storage in any retrieval system), transmitted by any means, electronic, mechanical, photocopy or otherwise, without prior written permission of the publishers.

Maps images derived from and reproduced from Ordnance Survey Ireland data are reproduced under OSI Licence Number, 2009/31/CCMA/ Meath County Council. Unauthorized reproduction infringes Ordnance Ireland and Government of Ireland Copyright.

**Copyright ©**

Copyright of the project examples and illustrations in this publication are retained by the respective architectural practices.

**Shay Scanlon Architects.  
Aughey O' Flaherty Architects.  
Paul Keogh Architects.  
Box Architecture.  
Box Urban.  
Taylor Architects.  
Boyd Cody Architects  
James Halpin Architects  
Patrick Gilsenan Architect**



1.

2.

3.

1. Newgrange
2. House Clonee
3. Thatched Cottage near Kells.

## **Foreword**

County Meath possesses high quality landscapes and a rich built fabric. The tradition of people living in rural areas in this County is long established and remains a popular option today. In the past the emphasis in Irish vernacular rural dwelling design was on good siting making use of available shelter, a simple design and use of local materials.

Meath County Council has commissioned this document, the County's first design guide for rural dwellings, in order to positively encourage the application of good siting and design principals to new single house development in the countryside.

It is our wish that the single house developments constructed in the countryside will be of an excellent standard, will compliment the landscape of the County of which they will form a part and will contribute in a positive manner to the built heritage of the County.

The guide recognises that rural dwelling design needs to respond to the requirements of the modern rural dweller. The guide therefore encourages the application of building forms that are from the traditional Irish vernacular as a reference in developing a design for a contemporary rural dwelling.

We would urge persons considering building a single house development to read this guide and take on board the many excellent proposals in it, in order to enhance the quality of life in County Meath for all its citizens.

**T Dowling**  
County Manager

**Cllr T Reilly**  
Chair Planning SPC



<p><b>1.0 Introduction</b> <span style="float: right;">P. 05</span></p> <p>1.1 Objectives of guide</p> <p>1.2 Definition</p> <p>1.3 Rural Housing Policy</p> <p><b>2.0 Site Selection</b> <span style="float: right;">P.07</span></p> <p>2.1 Minimum Criteria</p> <p>2.2 Landscape Characteristics</p> <p>2.3 Orientation &amp; Shelter</p> <p><b>3.0 Site Development</b> <span style="float: right;">P.19</span></p> <p>3.1 Site Layout</p> <p>3.2 Contours &amp; Sloping sites</p> <p>3.3 Entrances &amp; driveways</p> <p>3.4 Boundaries, Planting &amp; Trees</p> <p><b>4.0 Building Design</b> <span style="float: right;">P.33</span></p> <p>4.1 Building Form</p> <p>4.2 Height</p> <p>4.3 Scale &amp; Proportion</p>	<p><b>5.0 Construction &amp; Detailing</b> <span style="float: right;">P. 45</span></p> <p>5.1 Roof, Gutters &amp; Fascias</p> <p>5.2 Dormers &amp; Roof Lights</p> <p>5.3 Wall Finishes</p> <p>5.4 Windows &amp; Doors</p> <p>5.5 Extensions, Porches &amp; Conservatories</p> <p>5.6 Patios &amp; Balconies</p> <p>5.7 Garages</p> <p>5.8 Satellite Dishes &amp; TV Aerials.</p>	<p><b>6.0 Building Types</b> <span style="float: right;">P.69</span></p> <p>6.1 Traditional Cottages</p> <p>6.2 Bungalow &amp; Dormer Bungalows</p> <p>6.3 Storey and a half Houses</p> <p>6.4 Traditional Two Storey Houses</p> <p>6.5 Estate Houses</p> <p>6.6 Farm Buildings</p> <p>6.7 Contemporary Buildings</p> <p><b>7.0 Sustainability:</b> <span style="float: right;">P.81</span></p> <p>7.1 Alternative Energy Sources</p> <p>7.2 Building Energy Rating</p> <p>7.3 Building Regulations</p> <p><b>8.0 Appendix</b> <span style="float: right;">P.89</span></p> <p>8.1 Useful Contacts &amp; Websites.</p> <p>8.2 Reference Publications.</p> <p>8.3 Acknowledgments</p>
---	--	---



## 1.1 Objectives of guide

Commissioning the design and the construction of a one off house can be one of the most daunting and rewarding projects ever undertaken in a life time. This guide sets out to explain and illustrate on a step by step basis all the various elements that need to be considered, outlining aspects of good design, siting and detail. This guide should be read in conjunction with the Meath County Development Plan.

## 1.2 Definition

A rural dwelling is a house built on unzoned land situated outside the identified development boundaries of a town or village.

## 1.3 Rural Housing Policy

Development of a one off house in the country side is required to comply with Meath County Council's County Development Plan 2007 - 2013. Section 6.7 Rural Settlement Strategy of the County Development Plan sets out the criteria governing whether an applicant has a rural housing need or not.

Persons considering constructing a one off rural house are advised to familiarize themselves with this policy and satisfy themselves that they meet the criteria set out in the Development Plan. Any application for a one off rural house should be accompanied by a completed Local Needs form and appropriate supporting documentation. A copy of this Local Needs form along with the necessary planning application form and documentation can be downloaded from Meath County Council's web site: [www.meath.ie](http://www.meath.ie) or are available for collection from the Planning Department, Abbey Mall, Abbey Road, Navan, during public opening hours.

The Development Plan is also available on the above website or at the offices of the Planning Department.

### Pre-planning Clinics:

Meath County Council run comprehensive pre-planning clinics, for details and to arrange a pre-planning meeting please contact; The Planning Department, Meath County Council, Abbey Mall, Abbey Road, Navan. Co. Meath.

Phone: 046 9097000

Fax: 046 9097001

E-Mail: [Info@meathcoco.ie](mailto:Info@meathcoco.ie)

Guidance notes and details on preplanning clinics are available on the Council's Website. Planning and Development Guidance Note 1, outlines the documentation to be submitted in support of an application for a dwelling in a rural area.





### 2.1.1 SIZE:

The minimum site size required for a single dwelling is determined by the need to meet the minimum separation distances between the treatment system, the percolation area/polishing filter, the proposed house, any watercourse, lake, wells, neighbouring dwellings, site boundaries and roads.

The availability of a public water main/group scheme may assist in reducing the overall required site size. In general a minimum of 0.5 acres (2,024m<sup>2</sup>) is normally adequate however this may not always be sufficient to meet all minimum separation distances based on the permeability of the soil, the proposed site layout, its configuration or shape and the proposed occupancy of the house (p.e., population equivalent).

The plan size of the percolation area/polishing filter will be determined by the permeability of the in-situ soil on the site and the maximum potential occupancy of the house.

If an extension to an existing dwelling is proposed with a resulting increase in the maximum potential occupancy of the completed dwelling then the percolation area/polishing filter may have to be increased in size/plan area to cater for the increased loading. The capability and capacity of the existing septic tank or treatment system along with the associated percolation areas will need to be demonstrated to the satisfaction of the local Authority to determine whether they can cope with the increased maximum potential occupancy. This must be addressed in any planning application submission.

For the purposes of sizing a polishing filter the minimum area of a single bedroom is 6.5m<sup>2</sup> and that of a double bedroom is 10.2m<sup>2</sup>. In general a single room = 1 p.e. and a double or twin room = 2 p.e.

### 2.1.2 WASTEWATER TREATMENT:

If the site being considered is not served by a public sewer then waste water will need to be treated and disposed of on site (i.e. be treated in a treatment system before discharge to a percolation area/polishing filter with final discharge through the subsoil to groundwater). A full site assessment will need to be carried out in order to determine the suitability of the site to treat and dispose of wastewater from the dwelling.

As and from the 4<sup>th</sup> of August 2009 Site Characterisation Reports submitted for planning purposes need to be carried out by persons from the panel of approved site assessors. Details on this panel are available on the Meath County Council website [www.meath.ie](http://www.meath.ie). It should be noted that the assessors are not employed by Meath County Council and inclusion on the list only implies that the assessors have met the criteria for inclusion on the panel. Applicants are advised that the assessors are employed directly by them and that Meath County Council cannot take any responsibility for the quality of reports produced. It is recommended that the site assessor be consulted prior to any site layout plans being prepared to advise on the best location for the percolation area/polishing filter.

An initial site assessment should be carried out on the undisturbed in-situ soil on the proposed site and no site remediation/improvement works should be carried out without the benefit of planning permission. Where site remediation/improvement works are required and have been approved by the planning authority a further site assessment will need to be carried out once the improvement works have been completed (this will be contained in a condition of grant).

For information relating to on site wastewater treatment systems please refer to The Environmental Protection Agency Code of Practice Wastewater Treatment and Disposal Systems serving single houses (p.e. ≤ 10), published in 2009, or any future amendments/addendums to this Code, available from [www.epa.ie](http://www.epa.ie)

### 2.1.3 SIGHT LINES

In order to ensure safe access and exit to a dwelling site minimum clear and unobstructed lines of vision are required. Sight distances and stopping sight distances should be in compliance with current road geometry standards as outlined in the **NRA document Design Manual for Roads and Bridges (DMRB)**, specifically Sections TD 41/95 and TD 9/07.

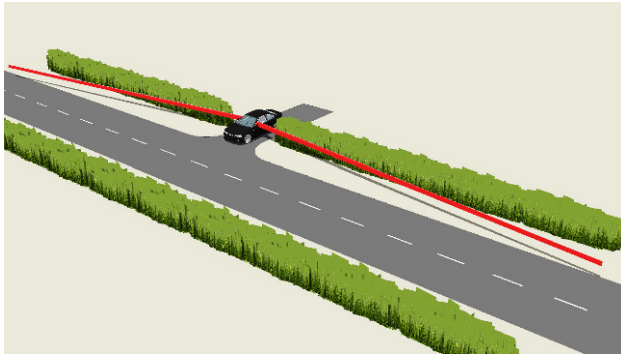

#### SIGHT LINES

Based on the design speed of the road the driver exiting will need to be able to view oncoming traffic for a safe distance in both directions, this line of vision is referred to as the sight line. It is measured at 2.4 M back from the edge of the road, this approximates to the position of the driver in the car. This set back distance needs to be increased to 4.5M in the case of a combined residential and agricultural entrance.

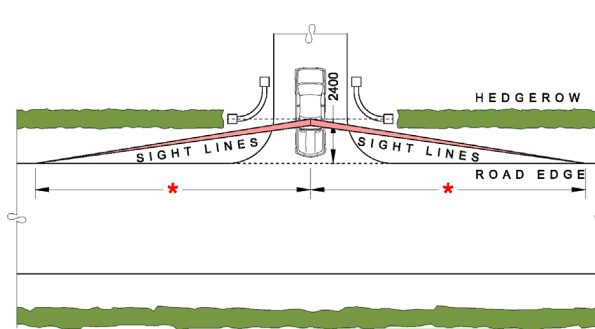

#### SIGHT LINES ON EXITING

- \* **Distance/length of unobstructed clear vision required. This distance/length is determined by the design speed for the section of road containing the access.**

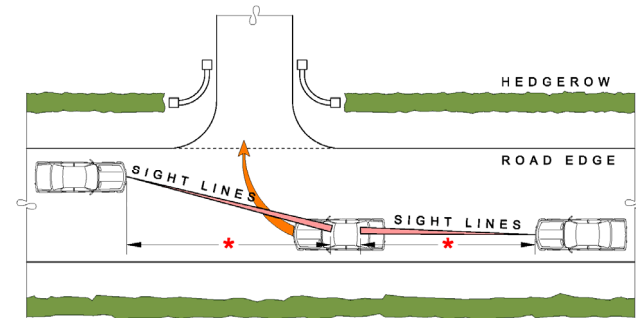

#### SIGHT LINES ON ENTERING

Forward and rear visibility need to be considered in order to ensure that the car waiting to turn in can be seen from a safe distance by a car approaching from the rear or in front.

- \* **The distance/length of visibility required by cars approaching from the front of rear**

New entrances on to certain roads are restricted by the NRA'S " Policy Statement on Development Management and Access to National Roads" Access to National Primary Routes is not permitted where the speed limit exceeds 60 Km p.h. , the document also points out that the same considerations apply to National Secondary Roads. Refer to section 6.7.9 of Meath County Development Plan 2007-2013.

Prior to progressing too far, an applicant, if in doubt should consult the Roads Department of Meath County Council on the suitability of the road to take a new residential vehicular access.

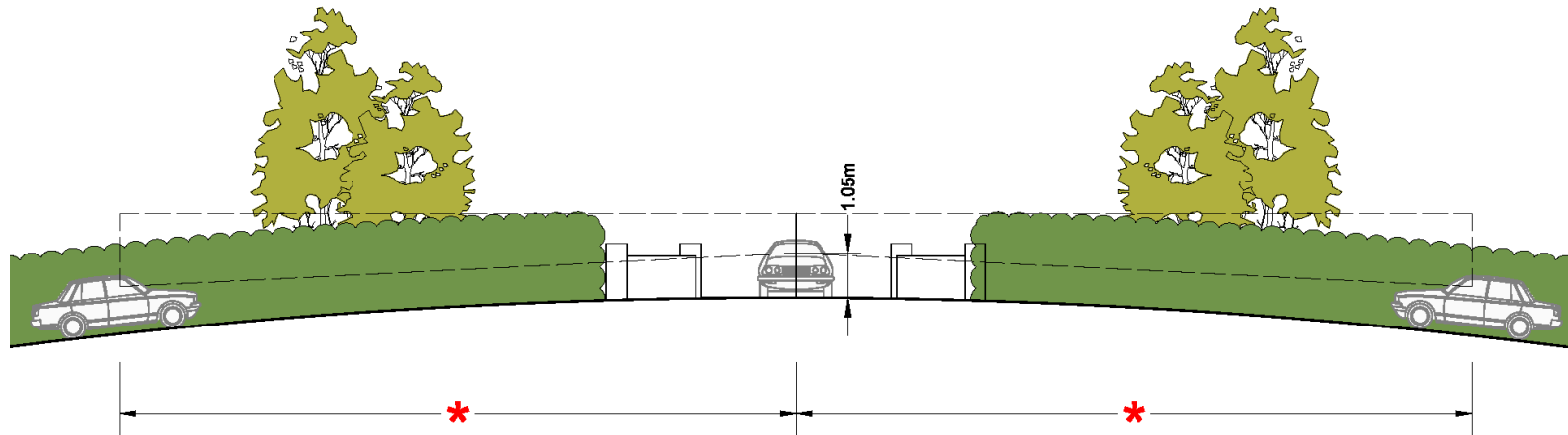

✓ SIGHT LINES: VERTICAL ALIGNMENT/VISIBILITY

- \* Distance/length of unobstructed clear vision required. If the road being accessed is not flat for the appropriate sight line distance on either side, then vertical sightlines need to be considered and demonstrated to the Planning Authority.

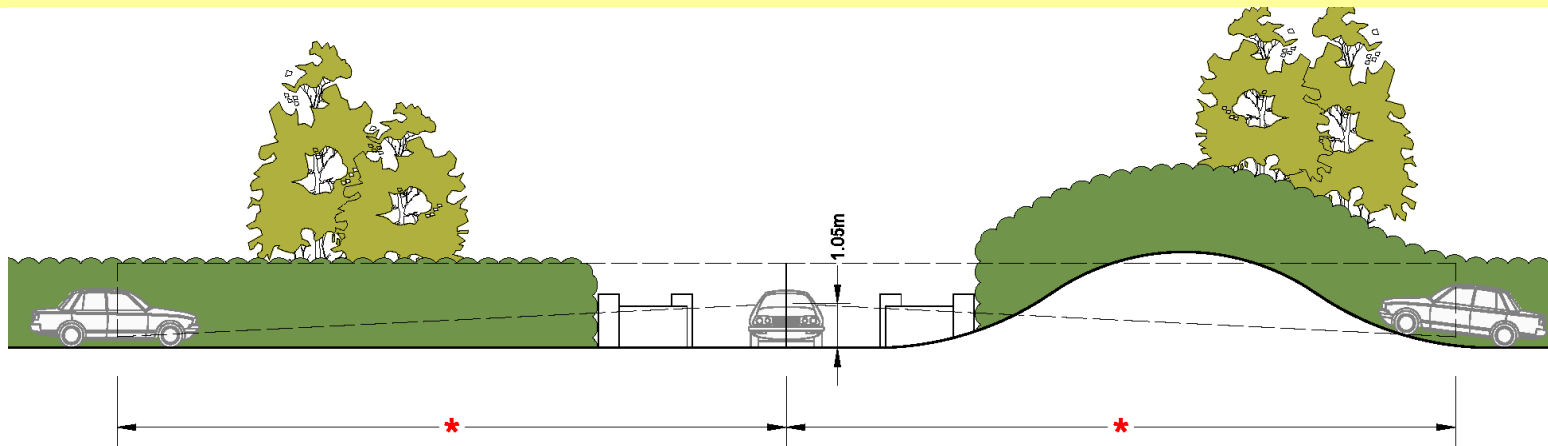

✗ Avoid: VERTICAL ALIGNMENT/VISIBILITY IMPAIRMENT

- \* Distance/length of unobstructed clear vision required. Vertical visibility impaired by contour of the road, sight line not achieved.

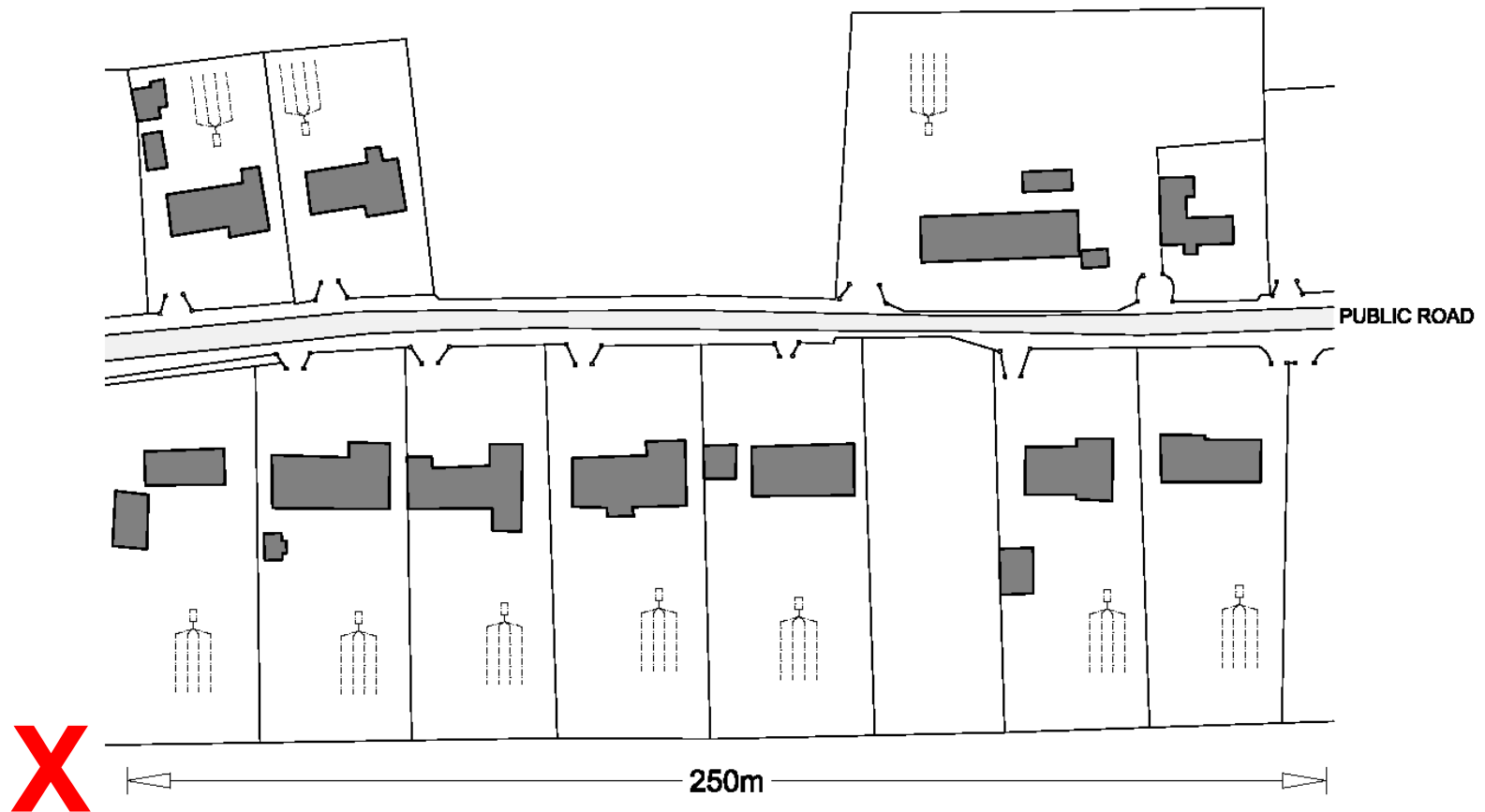

**X AVOID: RIBBON DEVELOPMENT /PROLIFERATION OF INDIVIDUAL ACCESSES:**

**Avoid** The proliferation of individual accesses along a section/length of rural road is to be avoided.

**Avoid** **Ribbon Development:** Where 5 or more houses exist on any one side of a given 250metres of road frontage then this is considered ribbon development.

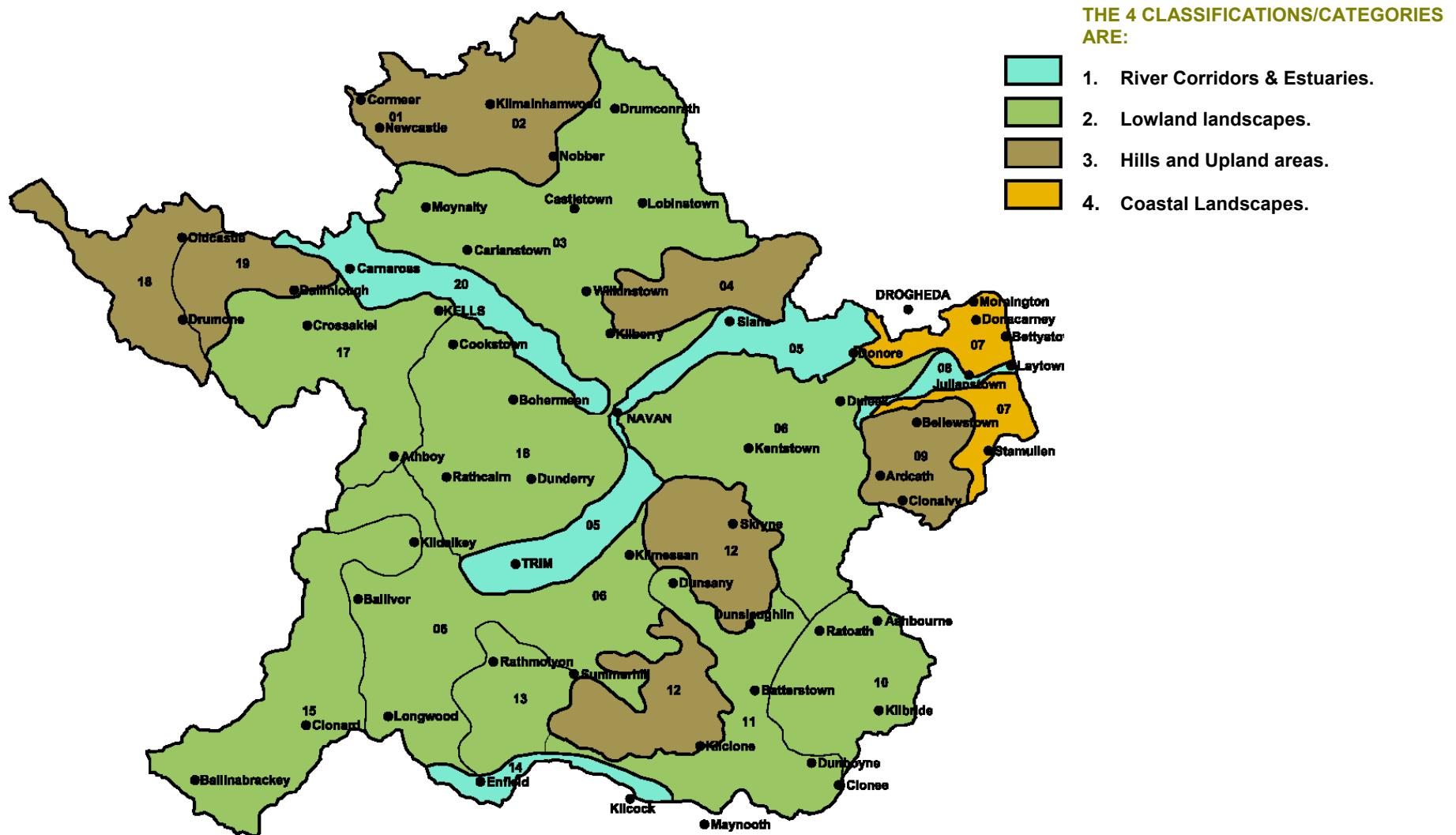

#### LANDSCAPE CHARACTERISTICS MAP OF THE COUNTY:

The 'Meath Landscape Character assessment' commissioned and published by Meath County Council is a detailed and in depth study, appraisal and characterization of the varying landscape typologies within the county. There are 4 differing classification/categories identified, refer to the map above. An applicant should familiarize themselves with this map and publication identifying the location of the site in relation to these categories. This will have a bearing on layout, design and siting of the proposed house. Refer to Meath County Development Plan 2007-2013, Appendix VI, Landscape Character Assessment.

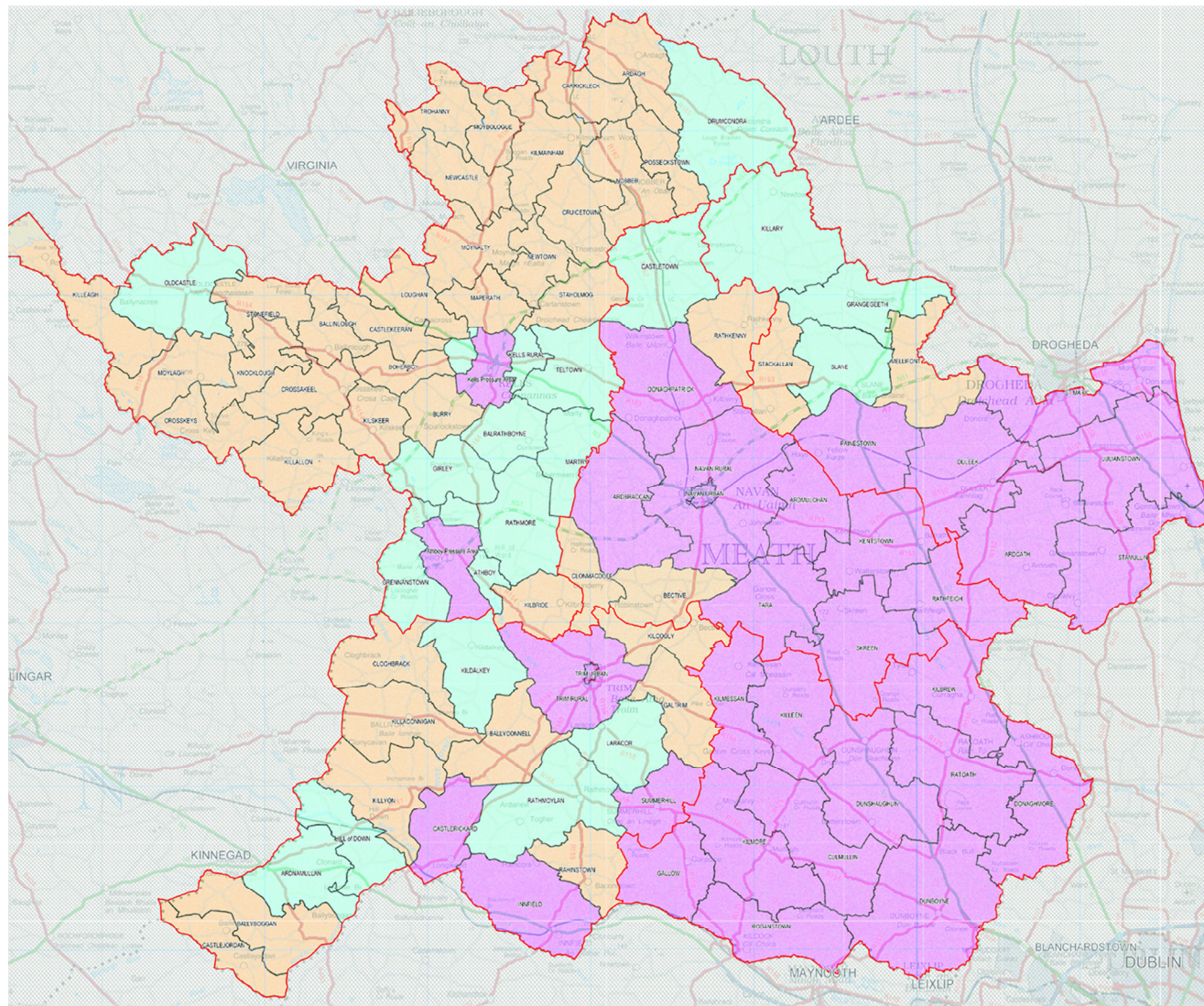
**KEY****Rural Area Type**

- Rural Area under Strong Urban Influence
- Strong Rural Area
- Low Development Pressure Area

**RURAL AREAS TYPES:**

The applicant should identify which rural type the proposed site falls within as this will determine how the application will be accessed in relation to Rural Development policies. Refer to Section 6.7, 'Rural Settlement Strategy' of the County Development Plan 2007-2013 for further guidance.

The orientation of the house and sizing of windows in relation to the path of the sun can provide significant benefits in relation to passive solar gain. **Orientating a house within 15 degrees of due South can achieve energy savings of up to 30%.** In orientating the house existing features of the surrounding landscape should be taken in to account such as trees, hedgerows and natural land forms which will buffer the house against harsher weather and prevailing winds. Existing features such as deciduous trees on the sunny side will help to shade the house from excess heat during the summer months, but allow the lower winter sun to reach the house provide free solar heat gain.

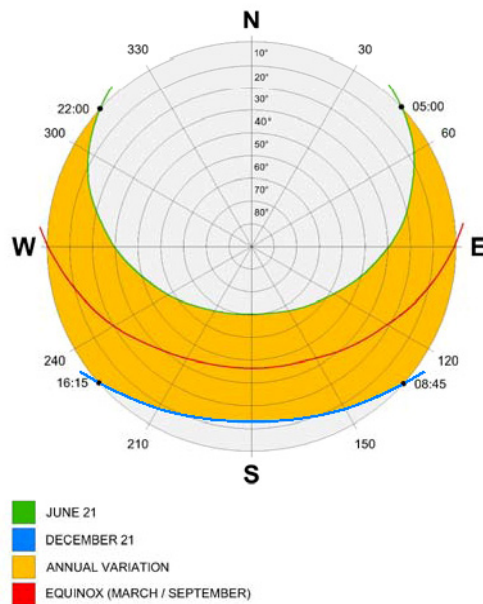

Sun path Diagram

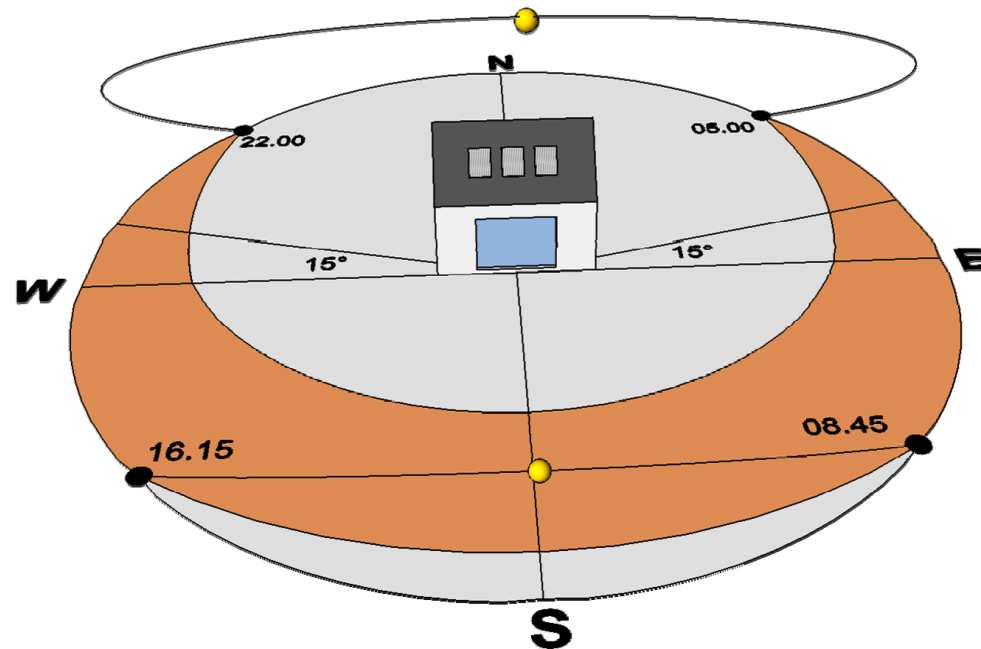

Sun path Diagram

Orientating a house with in 15 degrees of due South can achieve energy savings of up to 30%.

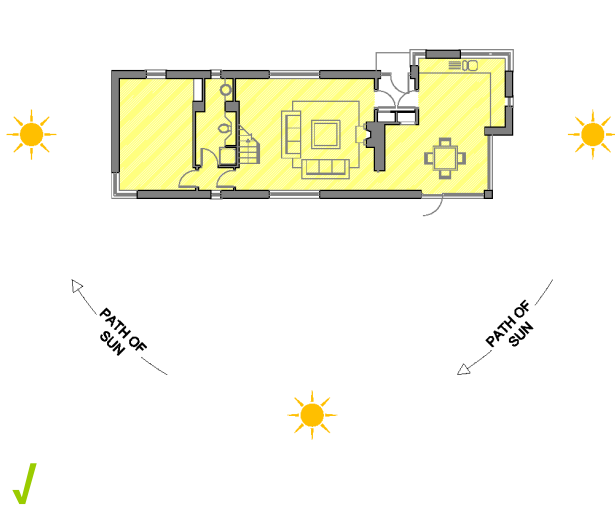

Advantages of the single room plan, sun to all rooms during the day.

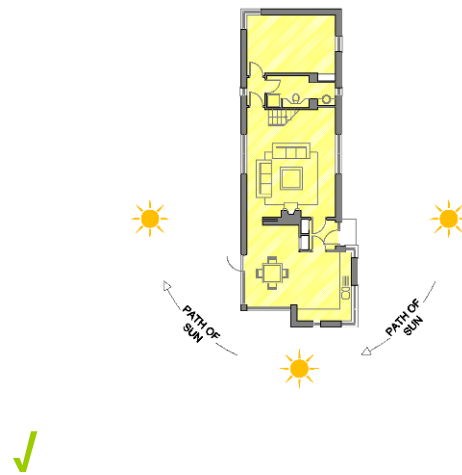

Single room plan can be orientated North South, rooms receiving direct sunlight from different aspects during the course of the day.

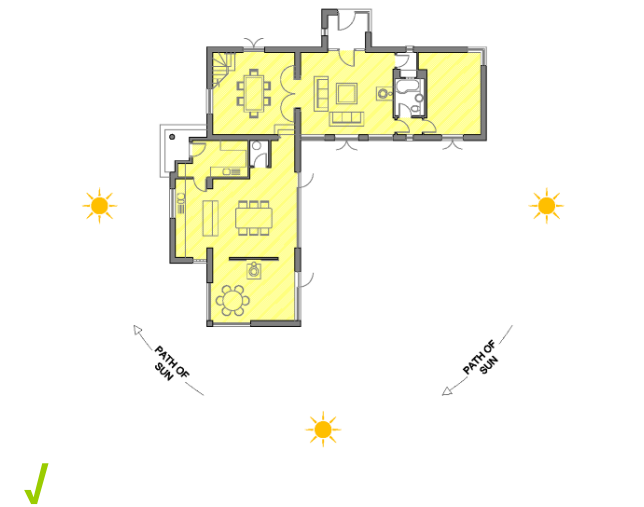

Benefits of L Shaped Plan, combines the benefits of the two earlier examples along with creating a partially enclosed sheltered, patio area.



Large window opens to South Elevation, to take advantage of solar gain.



Small window opens to North Elevation, to prevent heat loss.

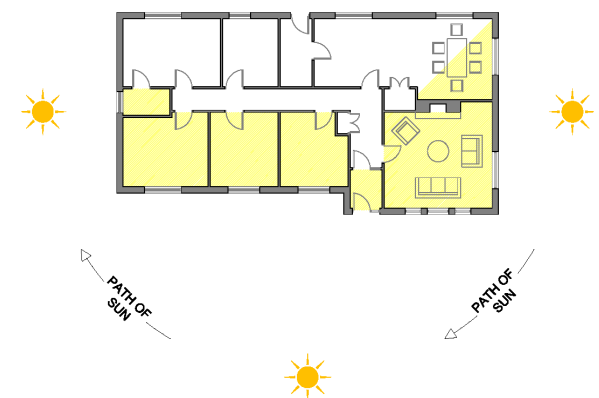

Typical bungalow plan orientated East West. Some rooms do not receive direct sunlight.

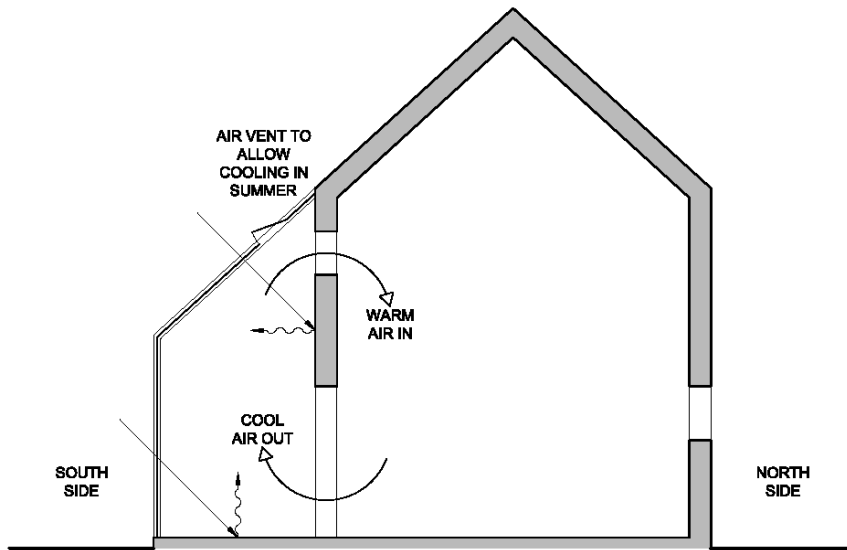

### ✓ PASSIVE SOLAR GAIN

Creating large glazed South facing elements which can be designed to assist with and regulate passive solar gain. Warm and cool air circulating by convection.

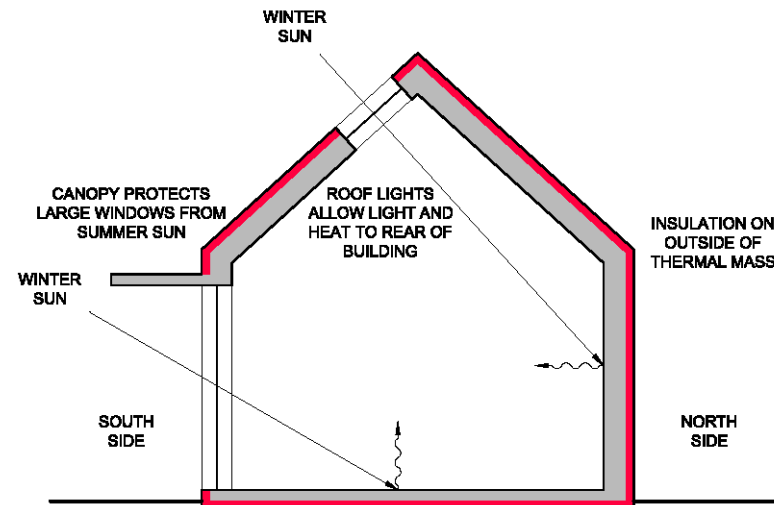

### ✓ PASSIVE SOLAR GAIN WORKING WITH THE BUILDING'S THERMAL MASS

The above illustrates the principals associated with passive solar gain. Large South facing windows and roof lights capture heat from the sun which is absorbed and stored in the building fabric, referred to as the building's thermal mass. The heat stored in the building fabric during the day radiates back into the rooms at night time.



Traditional two storey farm house, near Slane, well integrated and sheltered in the landscape.

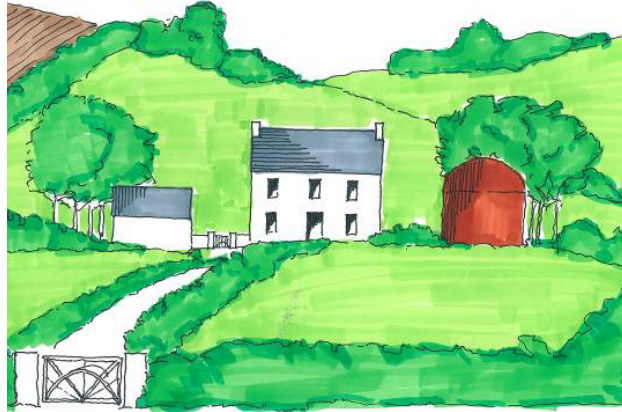

Traditional two storey farm house well integrated and sheltered, mature planting on either side. Sloping contour as back drop.



Recent built house, again well integrated and sheltered in its surroundings.



Benefit of shelter; Country farm house near Summerhill, house partially concealed by mature trees.



Benefit of shelter; Mature trees on the side of the prevailing winds.



Benefit of shelter; Country house near Summerhill almost completely concealed by extensive mature tree planting.

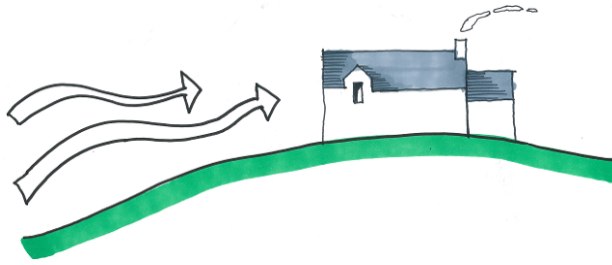

X

**Avoid** exposure to prevailing winds, locating the house on an exposed site with no wind break.



X

**Avoid** hilltops and prominent locations, the building should not be seen against the skyline.

X

**Avoid** flat open sites can also be adversely exposed to the prevailing winds if there is no planting.

**Avoid** exposure to the prevailing winds, their direction may vary from site to site due to the topography of the site, e.g. hill top or valley, and the existence of shelter belts provided by extensive hedgerow or tree planting.

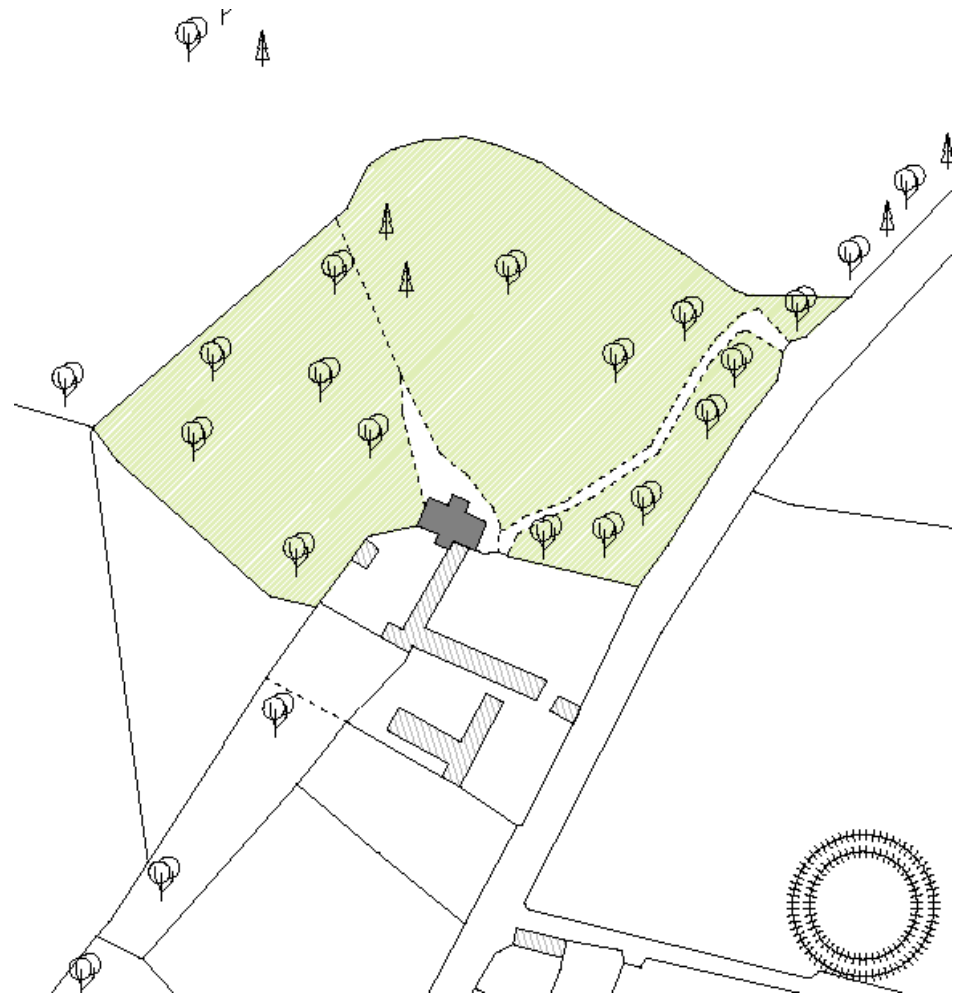

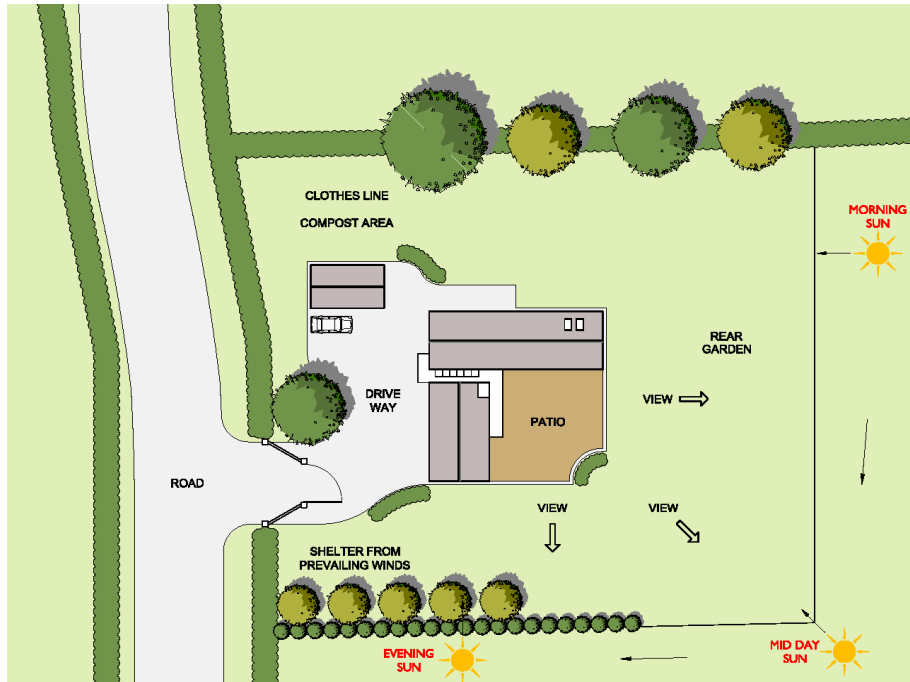

✓ Fig 3.1.1. Schematic layout on 2,024 sq.m. (½ acre) site:

'L' Shaped plan creates sheltered private open space which ground floor rooms can open out on to. Garage/fuel store used to create sheltered arrival space to the front.

#### SITE LAYOUT: FACTORS TO BE CONSIDERED;

- Position of the house on the site.
- Orientation of the house in relation to path of the sun and prevailing winds.
- House form and location should be used to create sheltered and easily accessible open spaces.
- Views from the house and views on approach, avoid over exposure of the house.
- Other buildings on the site, garage, workshop, fuel store and their relationship to the house.
- Allow for future extension
- Building lines and relationship to neighboring and adjoining buildings.

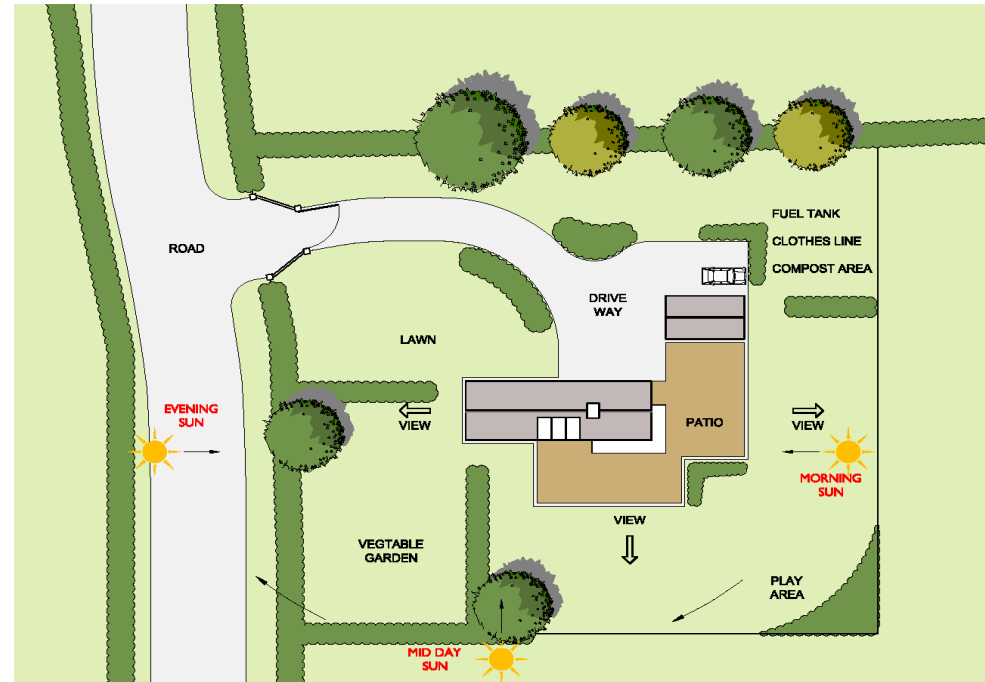

✓ Fig 3.1.2. Alternative Schematic layout on 2,024 sq.m. (½ acre) site:

House and garage situated in order to divide the site up into different functional areas.

- Safe play area.
- Privacy to open spaces, screening boundaries, hedgerows and planting.
- Vegetable gardens.
- Position for clothes line.
- Cables, satellite dishes and TV aerials.
- Position of entrance, driveway, access roads and hard standing for car parking, concealing parked cars.
- Access for deliveries, maintenance of treatment units etc.
- Refuse storage and recycling/compost areas.



Site layout plan of typical period rural house set back from the public road and its relationship to its grounds and out buildings



Tree lined drive with discreet entrance gateway.



Two houses clustered together on the same site with shared entrance and driveway.

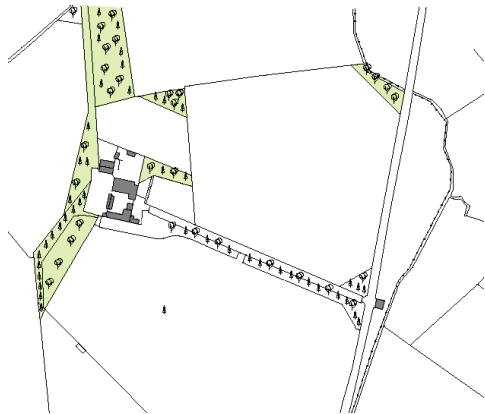

Site layout plan of typical period rural house set back from the public road with long tree lined drive way, shelter planting.

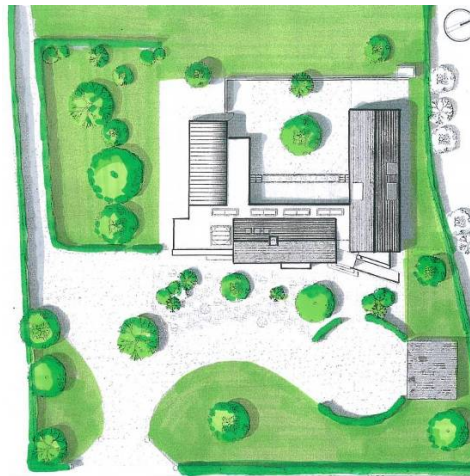

Site layout plan of house at Culmullen.



Site layout plan of typical period rural house set back from the public road with drive way, shelter planting around house.

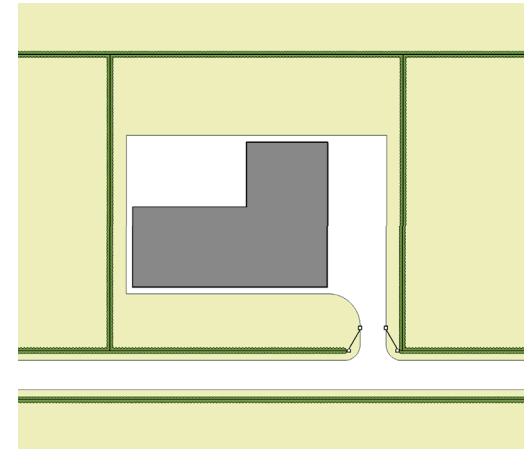
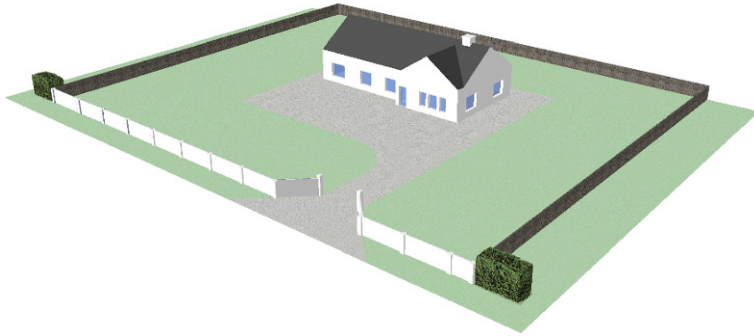

X

**Avoid:** Common Approach, Bungalow placed in the middle of a half acre plot, front elevation parallel with the main road, with no relationship with its surrounding, or external spaces, no sheltering and no privacy.

X

**Avoid:** Building layout and size too big for the site.

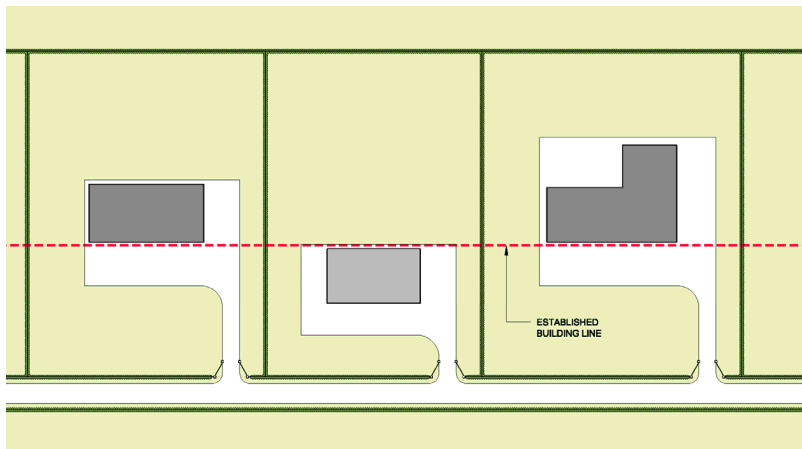

X

**Avoid:** Building in the backlands behind established dwelling.

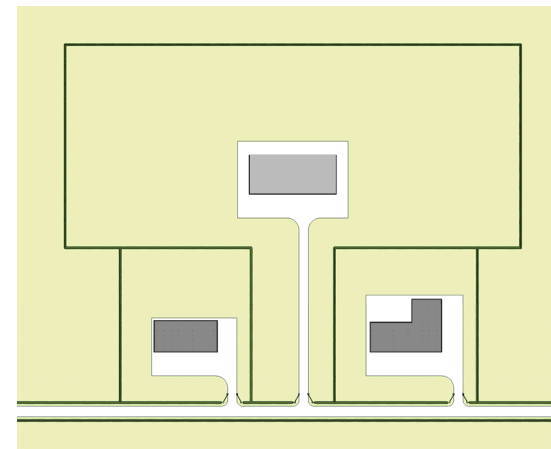

X

**Avoid:** Building in backlands behind existing dwellings, development of this type can compromise the private residential amenity of existing and established dwellings.

THE APPROACH, DOS AND DON'TS TO CONTOURED AND SLOPING SITES.

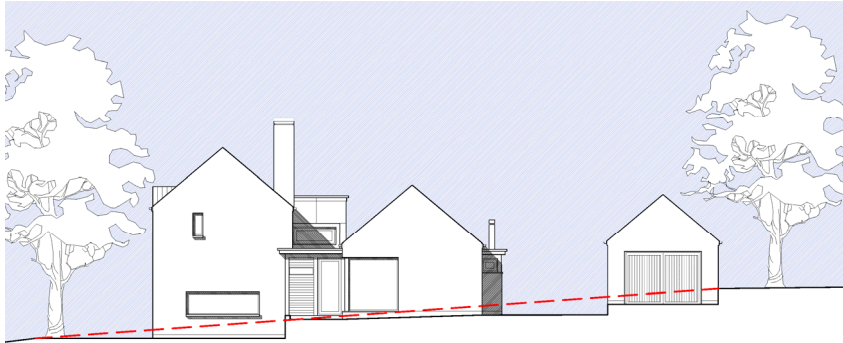

Contemporary house on a inclined site designed with reference to traditional forms, main access of the house running parallel with the site contours with the plan stepped.

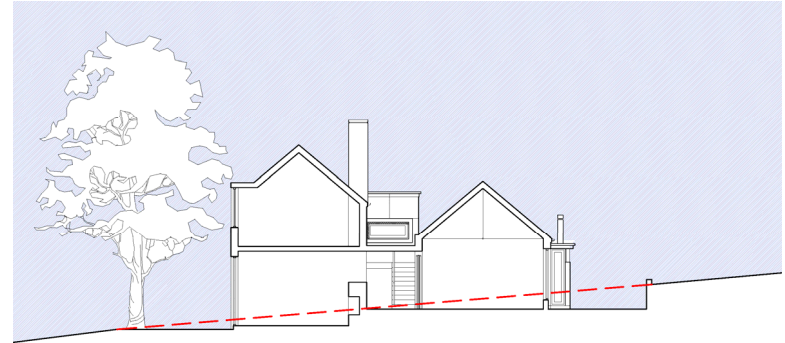

Split level plan responding to the contour of the site.

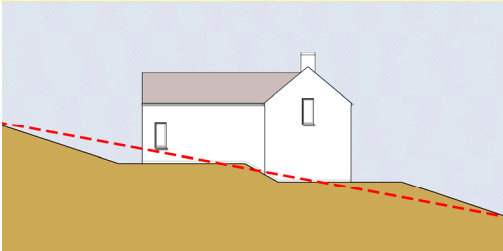

House designed to step with the slope cut and fill kept to a minimum

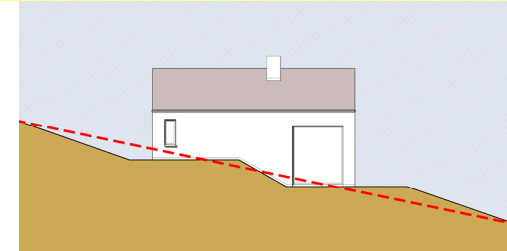

Split level House

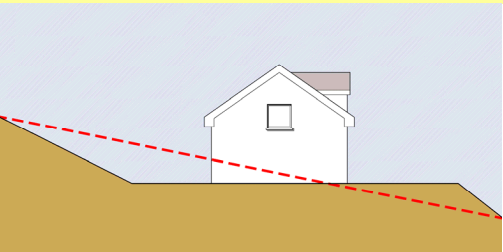

**Avoid** Large cut into landscape and large landfill platform to the front.

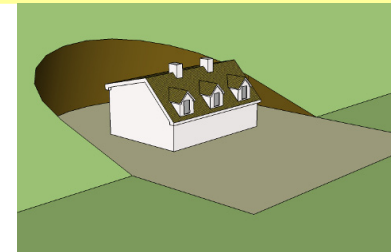

**Avoid** Large cut into landscape and large landfill platform to the front.



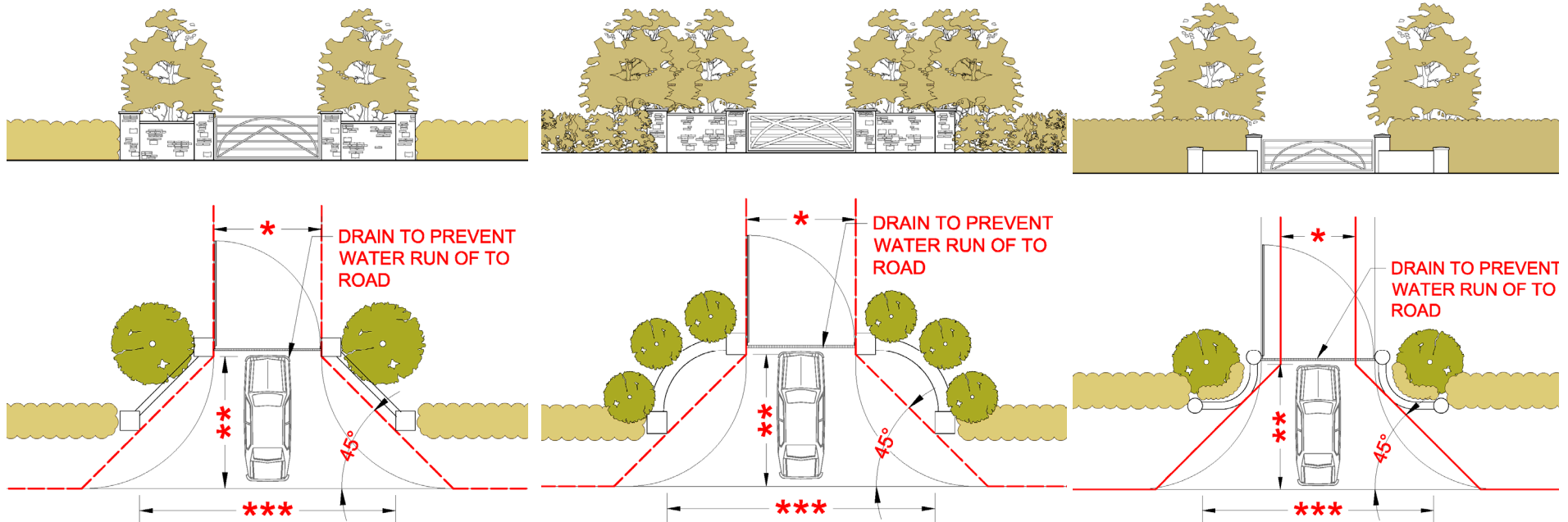

✓ The above are examples of good design and acceptable approaches to entrance gateways, piers and side walls.

- \* Allow for a comfortable width, not too wide or too narrow. 3m approx should be sufficient.
- \*\* Allow a safe depth for the car to pull in fully and not overhang the edge of the road, approx 4.8m to 5 m.
- \*\*\* The width of the opening at the road edge to be kept to a minimum allowing for clear sightlines, approx 8m at fence line.

To avoid a proliferation of access points sharing of entrances should be considered where appropriate.

The location of post boxes, intercoms and security cameras should be discreet.

It is the responsibility of the Developer to cater for drainage of surface water from the public road if the site is lower than the road. If the site is higher than the road the developer must prevent surface water from the site running onto the public road.

**Avoid** the removal of large sections of hedgerow.

**Avoid** over scaled, elaborate and ostentatious designs. Keep materials and finishes to a minimum

**Avoid** ornamentation.

**Avoid** unnecessary lighting of entrances and driveways.



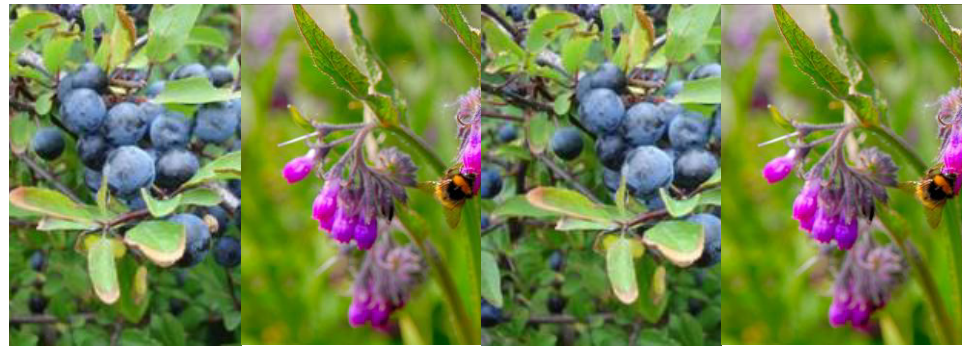



✓ Existing hedgerows should be retained and augmented with similar planting where necessary to maintain cover and habitats.

Landscaping proposals and details should be submitted with a planning application. The level of detail and extent of planting required will be determined by the existing and nature of planting available, the exposure of the site and the sensitivity of the landscape.

On sites where significant landscaping and planting may be required to support an application then detailed drawings and proposals along with details of shrubs, trees and their level of maturity should be provided by a suitably qualified person or company.

✗ **Avoid** the removal of extensive sections of hedgerow.

The Forestry Act 1946 contains the main provisions for the felling of trees. Under this act it is an offence for any person to uproot or cut down any tree unless the owner has obtained permission in the form of a felling license from the Forest Service.

✗ **Avoid** extensive man made boundaries, such as masonry or stone walls, timber or metal fencing.

### NEW BOUNDARY PLANTING

Below are a list of trees and shrubs suitable for countryside hedgerows and shelterbelts. This list is not exhaustive, but gives an indication of some of the appropriate species to consider when planting for shelter.

NAME	SUITABILITY	ADVANTAGES	DISADVANTAGES	SUITABLE FOR HEDGES	RATE OF GROWTH	HEIGHT
<b>Alder</b> <i>Alnus glutinosa</i>	Grows in a wide variety of soils, prefers damp or waterlogged conditions	Fast growing, easy to establish, good in clay, fill and wet soils	Will not flourish in stagnant water.	Not applicable	Fast	10.5 M 35 ft.
<b>Ash</b> <i>Fraxinus excelsior</i>	Grows in a wide variety of soils, open woodland.	Good in windswept, exposed and coastal sites	Will not grow in shade	Not applicable	Fast	18 M 60 ft.
<b>Aspen</b> <i>Populus tremula</i>	Tolerates/prefers damp conditions.	Tolerates poor soils, suitable in exposed areas.	Invasive, not suitable close to buildings or services.	Not applicable	Not applicable	20 M 65 ft.
<b>Birch, Silver</b> <i>Betula pendula</i>	Grows in a wide variety of soils, open and woodland sites	Good in damp and poor soils, for sheltering slower growing species.	Not applicable	Not applicable	Slow	30 M 100 ft.
<b>Birch, Downy</b> <i>Betula pubescens</i>	Grows in a wide variety of soils, open and woodland sites, tolerates damp conditions	Good in damp and poor soils, for sheltering slower growing species.	Not applicable	Not applicable	Not applicable	25 M 80 ft.
<b>Blackthorn / Sloe</b> <i>Prunus spinosa</i>	Grows in a wide variety of soils, hedgerows, woods, banks and dense thickets	Good in stoney soils, windswept, exposed and coastal sites.	Invasive.	✓	Medium	7.5 M 25 ft.
<b>Cherry, Wild</b> <i>Prunus avium</i>	Grows in a wide variety of soils, woods and hedgerows	Attractive blossom and foliage, easily established	Not applicable	✓	Not applicable	25 M 80 ft.
<b>Crab Apple</b> <i>Malus sylvestris</i>	Grows in a wide variety of soils. Good in hedgerows	Attractive blossom, form and foliage, easily established	Requires open location	✓	Not applicable	10 M 32 ft.
<b>Elder</b> <i>Sambucus nigra</i>	Grows in a wide variety of soils. Good in hedgerows and woodlands	Fast growing, tolerates exposed conditions. Berries edible	Invasive.	✓	Fast	3.6 M 12 ft.
<b>Elm, Wych</b> <i>Ulmus glabra</i>	Good in hedgerows and woodland	Fast growing, tolerates exposed conditions	Dislikes dry sites, prone to Dutch Elm disease	Not applicable	Not applicable	40 M 130 ft
<b>Gorse, Common</b> <i>Ulex europaeus</i>	Hedgerows and scrub	Evergreen, fast growing, good protection for saplings	Invasive.	✓	Not applicable	3.6 M 12 ft.
<b>Guelder rose</b> <i>Viburnum opulus</i>	Hedgerows and woodland edges. Tolerates/prefers damp conditions	Attractive blossom, form and foliage, tolerates shade.	Not applicable	✓	Not applicable	2 to 4 M 3 to 13 ft.
<b>Hawthorn</b> <i>Crataegus monogyna</i>	Grows in a wide variety of soils, hedgerows and scrub	Good protection for saplings, deters livestock and tolerates shade.	Dislikes wets sites and acid soils	✓	Medium	7.5 M 25 ft.

NAME	SUITABILITY	ADVANTAGES	DISADVANTAGES	SUITABLE FOR HEDGES	RATE OF GROWTH	HEIGHT
<b>Hazel</b> <i>Corylus avellana</i>	Grows in a wide variety of soils. Hillsides, woodland understory	Coppices easily, prevents erosion of thin, hillside soils, tolerates shade.	Dislikes acid soils	✓	Not applicable	1 to 6 M 3 to 20 ft.
<b>Holly</b> <i>Ilex aquifolium</i>	Grows in a wide variety of soils, Woodlands	Evergreen, tolerant of exposure, tolerates shade.	Dislikes wet sites, difficult to establish	✓	Slow	7.5 M 25 ft.
<b>Honeysuckle</b> <i>Lonicera periclymenum</i>	Grows in a wide variety of soils. Climber good in hedgerows	Attractive flowers, hardy.	Not applicable	✓	Not applicable	5 M 16 ft.
<b>Oak</b> <i>Quercus</i>	Grows in a wide variety of soils. Best on its own or in groups	Tolerates shallow, rocky soils, very wind firm	Needs shelter when young, needs a large site.	Not applicable	Medium	15 M 50 ft.
<b>Holm Oak (Green oak)</b> <i>Quercus ilex</i>	Grows in a wide variety of soils. Best on its own or in groups, Evergreen.	Tolerates shallow, rocky soils, very wind firm	Needs shelter when young, needs a large site.	Not applicable	Medium	15 M 50 ft.
<b>Privet</b> <i>Ligustrum vulgare</i>	Hedgerows	Easily established, attractive flowers, Semi-evergreen.	Not applicable	✓	Not applicable	4 M 13 ft.
<b>Rowan (or Mountain Ash)</b> <i>Sorbus aucuparia</i>	Grows in a wide variety of soils. Woodlands, hillsides	Hardy, tolerant of exposure, attractive flowers and berries	Prefers dry sites	Not applicable	Not applicable	20 M 65 ft.
<b>Whitebeam</b> <i>Sorbus Intermedia</i>	Woodland, rocky ground	Hardy, tolerant of exposure, attractive flowers and foliage	As Rowan but better tolerance of damp soils	Not applicable	Not applicable	6 M 20 ft.
<b>Willow/Sally</b> <i>Salix</i>	Grows in a wide variety of soils. Stream sides and damp sites	Fast growing, good shelter and screen trees	Cannot survive permanent waterlogging	✓	Fast	27 M 90 ft.

Non-native trees (introduced naturalised species)						
NAME	SUITABILITY	ADVANTAGES	DISADVANTAGES	SUITABLE FOR HEDGES	RATE OF GROWTH	HEIGHT
<b>Beech</b> <i>Fagus sylvatica</i>	Single trees, shelter belts	Salt tolerant, will grow in shade	Grows best when 'nursed'	✓	Not applicable	40 M 130 ft
<b>Fuschia</b> <i>Fuschia magellanica</i>	Good in hedgerows	Attractive flowers and foliage	Not applicable	✓	Fast	2.4 M 8 ft.
<b>Lime</b> <i>Tilia vulgaris</i>	Single trees, woodland	Attractive form	Needs shelter when young	Not applicable	Not applicable	40 M 130 ft
<b>Horse Chestnut</b> <i>Aescus hippocastanum</i>	Woodland, single trees	Attractive form, flowers and autumn colour	Not applicable	Not applicable	Not applicable	35 M 115 ft
<b>Sweet chestnut</b> <i>Castanae sativa</i>	Woodland	Fast growing, easily coppiced	Suffers from cold and exposure	Not applicable	Fast	12 M 40 ft





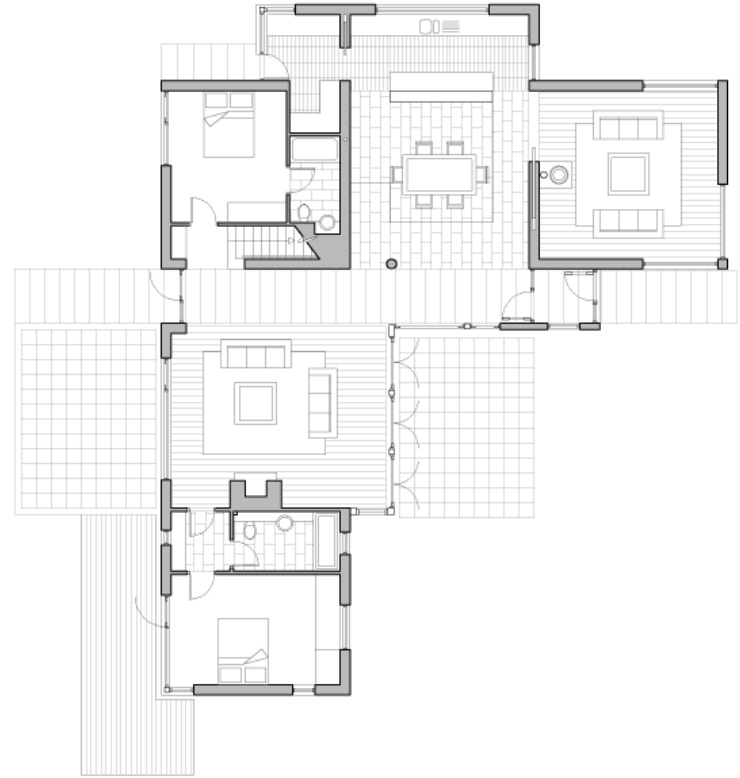

**DESIGN STATEMENT**

All planning applications should be accompanied by a detailed design statement outlining the rationale of the proposed design and how it adheres to the Meath Rural House Design Guide.

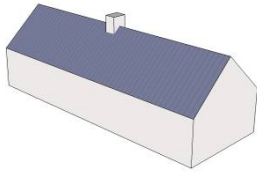

✓ Traditional single narrow plan cottage. Strong simple form.

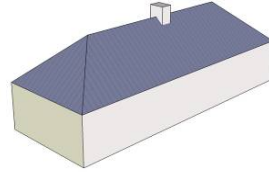

✓ Traditional single storey narrow plan cottage, hipped roof.

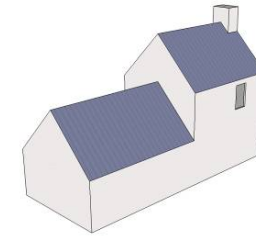

✓ Traditional form part single storey, part two storey.

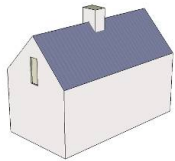

✓ Storey and half cottage.



✓ Storey and a half 'v' shaped dormer.

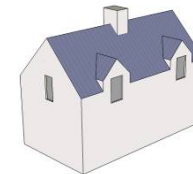

✓ Traditional storey and half dormer cottage.

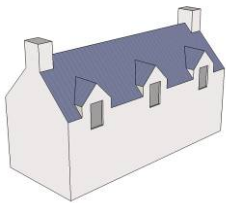

✓ Slightly larger traditional storey and half dormer cottage.



✓ Traditional two storey farm house

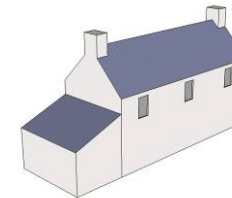

✓ Two storey house with side lean-to.

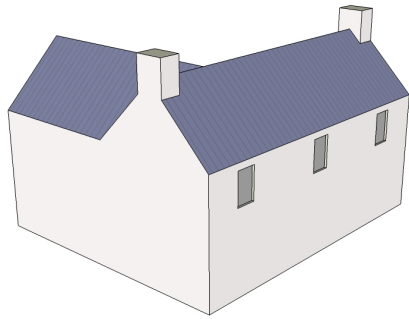

✓ Two storey farm house 'L' Shaped.

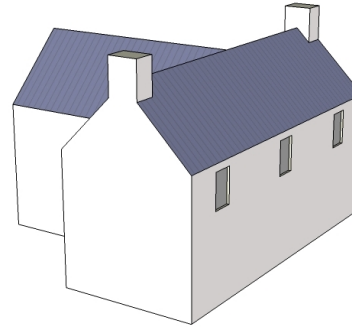

✓ Two storey farm house 'T' Shaped.

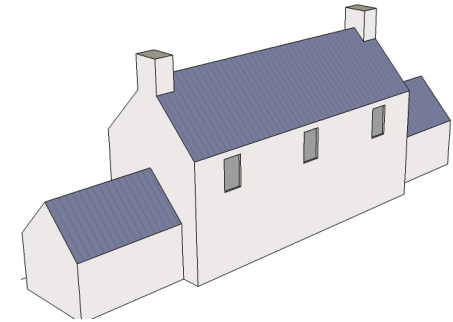

✓ Two storey farm house side annexes.

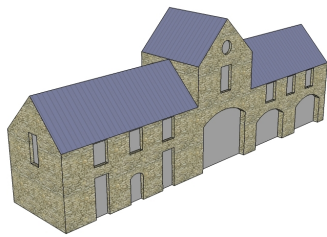

✓ Stone coach house and pigeon loft.

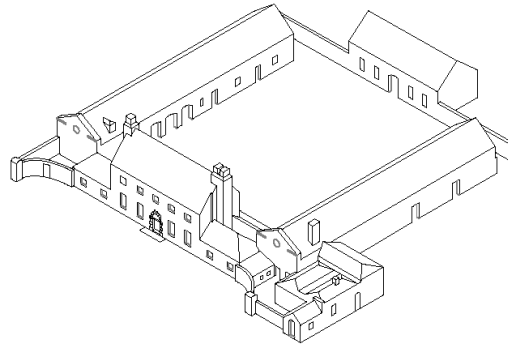

✓ Estate house Kilcarty Co. Meath, with courtyard

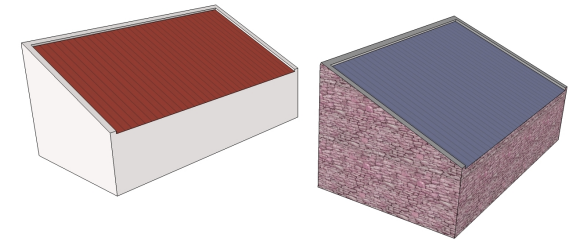

✓ Mono pitch form, usually farm buildings.

The building forms outlined on the previous two pages are from the traditional Irish vernacular, many fine examples of which still exist around the county. These forms can be used as a reference in developing a design for a contemporary rural dwelling. The elements that make these buildings successful and acceptable are their clear, simple, unambiguous and distinct form, they are well proportioned and are simply detailed. They create strong identifiable forms in the landscape.

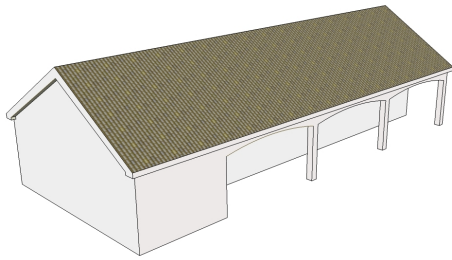

**X** Avoid: Typical single storey Bungalow.

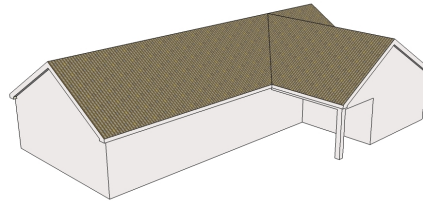

**X** Avoid: Typical 'L' Shaped Bungalow

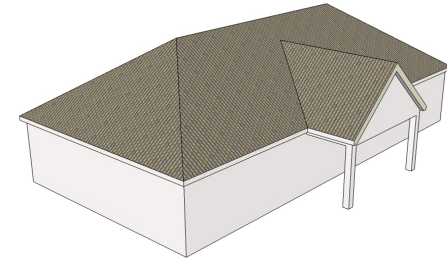

**X** Avoid: Typical Bungalow, hipped bungalow.

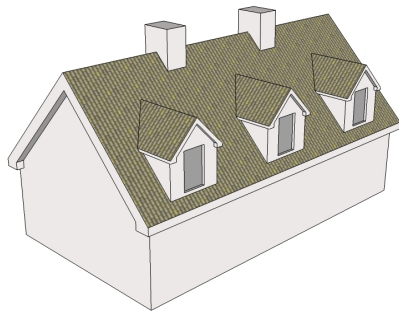

**X** Avoid: Typical Dormer Bungalow.

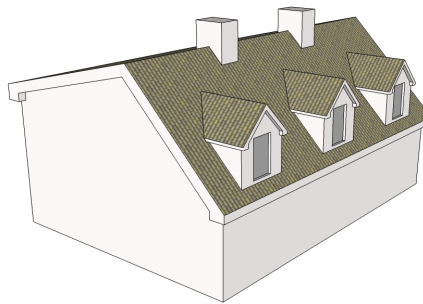

**X** Avoid: Non symmetrical roofs.

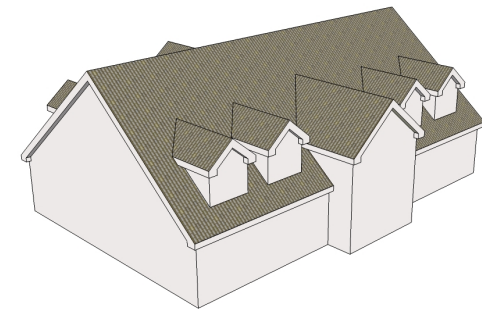

**X** Avoid: Deep plan bungalow.

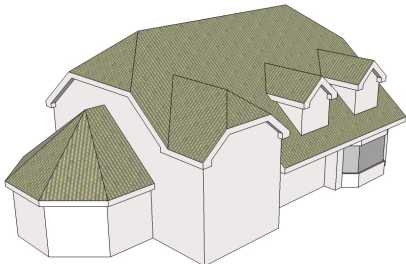

**X** Avoid: Clumsy and over elaborate forms

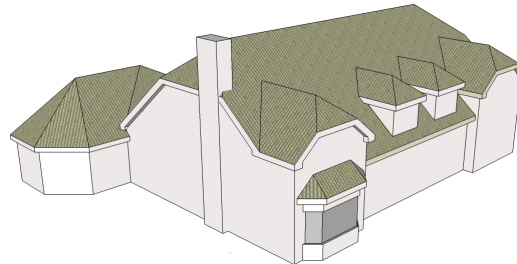

**X** Avoid: Clumsy & over elaborate form

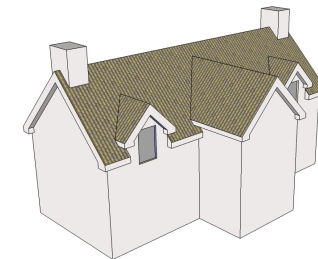

**X** Avoid: Two storey dormer with projecting central bay.

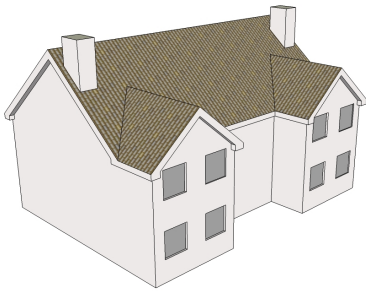

**X** Avoid: Large two storey with projecting bays.

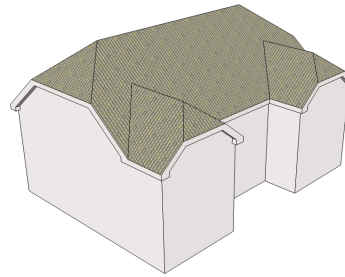

**X** Avoid: Large two storey hipped, dutch, gable roofs.

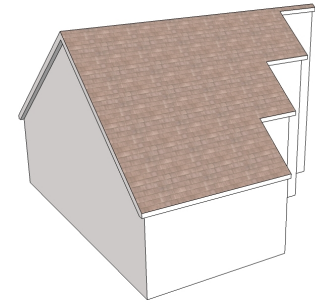

**X** Avoid: Large elaborate form.

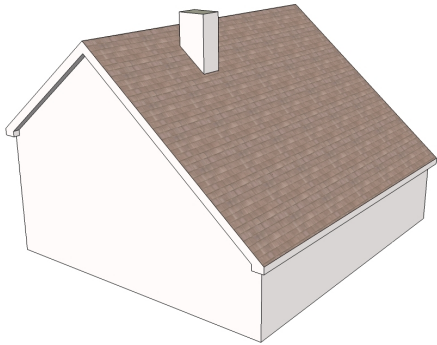

**X** Avoid: Asymmetrical gable fronted form.

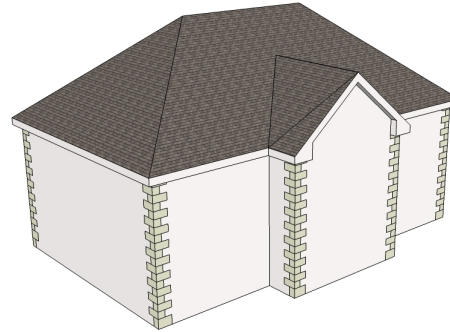

**X** Avoid: Badly proportioned mock Georgian form.

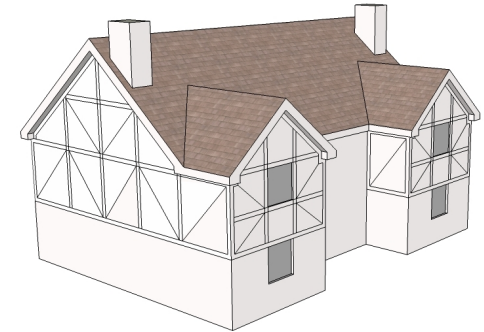

**X** Avoid: Mock Tudor and other non traditional forms.

Create strong simple forms with a reference to vernacular/ traditional houses and other strong well established rural buildings.

Over complex roof profiles and large overhangs reduce the impact of the building form.

Larger houses should control massing, overall scale and bulk by using various smaller elements/forms appropriately and sensitively linked and combined together.

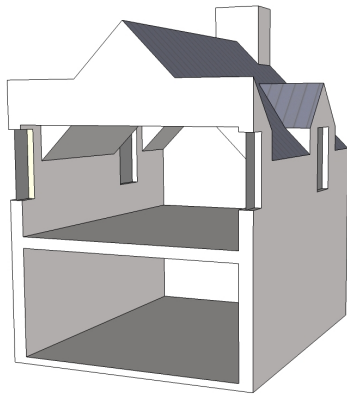

Storey and Half form; Provides a better use of the available first floor area, better head heights and quality of daylight through windows when compared to the dormer bungalow form.

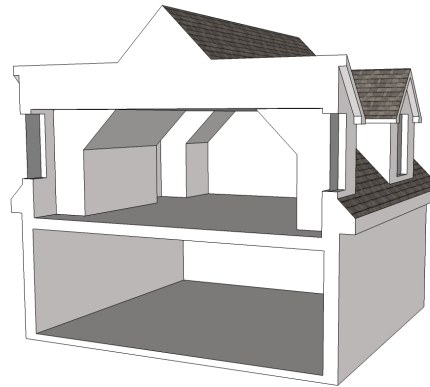

**X** Avoid:

Dormer bungalow form: Loss of effective first floor space, restricted head height. Often long deep recess to windows with resulting reduction in daylight penetration.

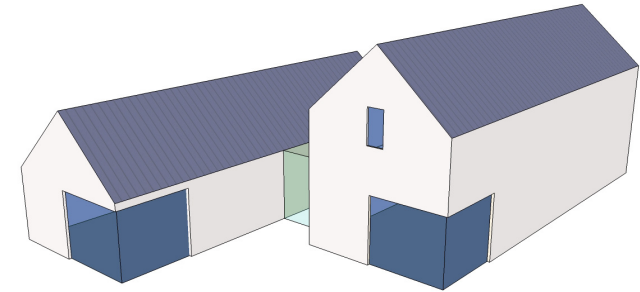

Approach to accommodating larger house requirements. Break building up in to a number of elements. Two shallow plan forms arrange parallel to each other with light weight link.

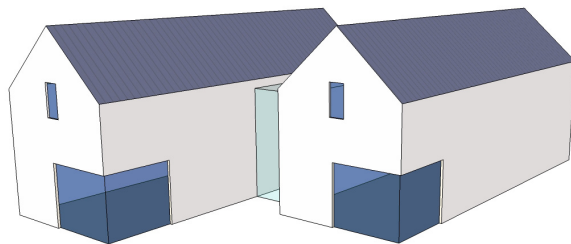

Two storey forms linked.

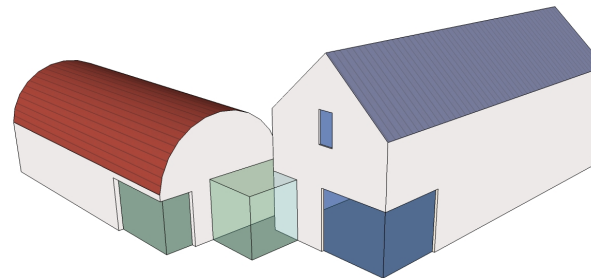

L shaped layout, two distinct forms.

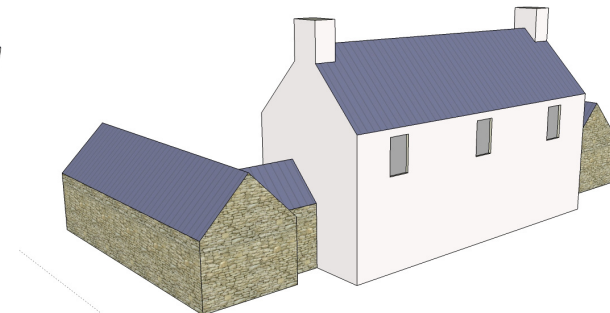

Main two storey form with single store side wings.

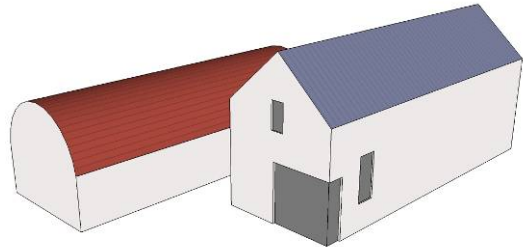

✓ Contemporary composition using traditional forms.

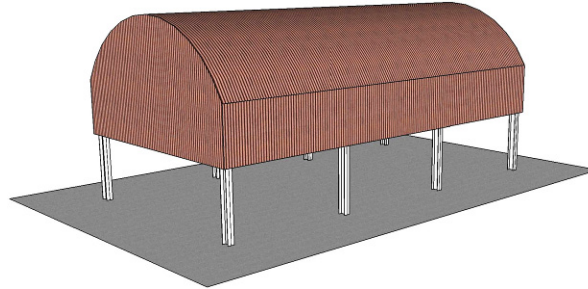

✓ Traditional corrugated shed form.



✓ Traditional corrugated shed form.

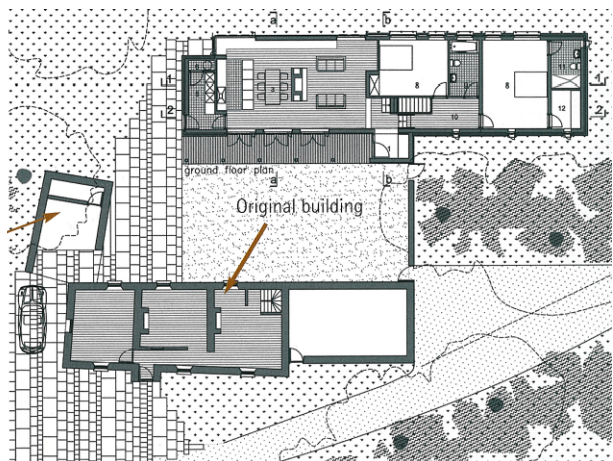

✓ Single depth room plan, new house arrange parallel to existing, creating courtyard space



✓ Contemporary house using barrel roof form.

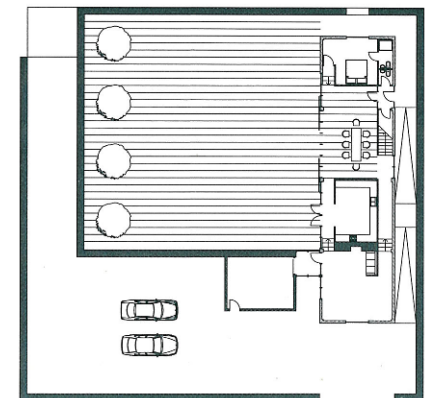

✓ Plan of proposed conversion of the shed pictured above to a dwelling house.

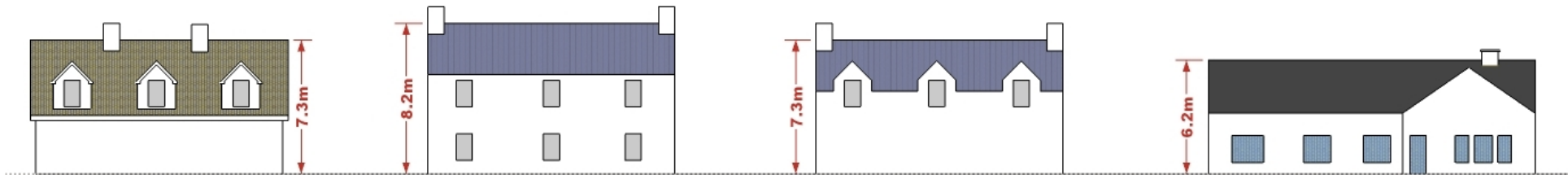

X

Typical Dormer Bungalow. First floor space and head height are compromised in this building type.

✓

Traditional two storey house

✓

Traditional Storey and half house.

X

Typical Bungalow.

The two traditional forms illustrated above are similar in height or slightly taller than the dormer bungalow, however their first floor plan and layout is not compromised by deep set dormers and reduced and sloping ceiling heights as in the dormer bungalow.



X

Typical Large Dormer Bungalow, Roof heights can be excessive due to deep plan.

✓

Traditional two storey house.

✓

Traditional Storey and Half house.

X

Typical two storey, deep plan.

In general the maximum height of a house will be determined by its siting, location and context. It should not dominate its surroundings. If the proposed house is located with single storey houses in close proximity on adjoining sites the overall height to the overall height to the ridge should be controlled and restricted to take account of the neighboring properties. The overall ridge height of any house should take account of its surroundings and topography, the overall height should not result in the building dominating its surroundings.

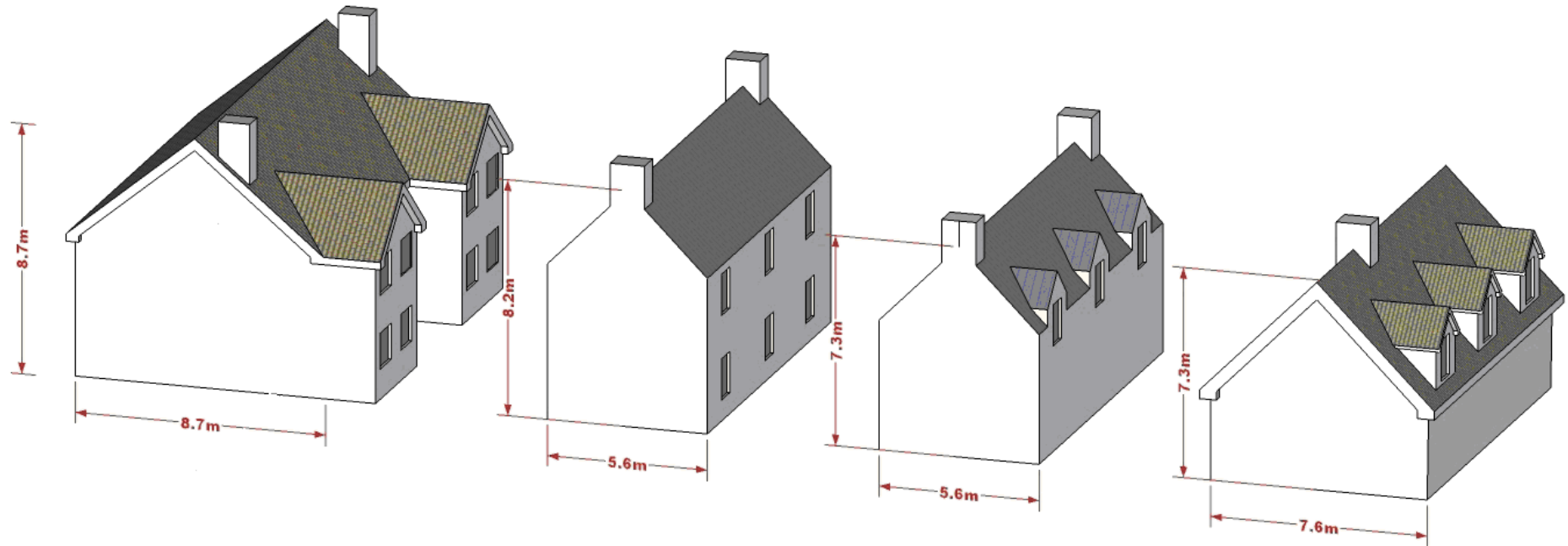

X

Deep plan form, creating over dominant gable and resulting higher ridge height

✓

Traditional two storey house. Shallower plan form resulting in well proportioned gable and good ridge height.

✓

Traditional Storey and Half house. Well proportioned roof relative to wall.

X

Typical dormer bungalow, deep plan form. Large roof form with resulting poor return in terms of qualitative first floor rooms and spaces.

The illustration above shows the comparative heights of various types/forms and also illustrates the impact that their overall plan depth has on the ridge height. This guide does not set out to establish a maximum height as the overall acceptable height of the proposed building will be determined by it's design, setting, context, proportion, massing and composition of the building forms.

There is a belief that there is a natural occurring proportioning system in nature, and the world around us, it is also believed that the human eye has been or is conditioned to appreciate this proportioning system and on the basis of this we determine whether an object is beautiful or not.

This system is often referred to as the 'Golden Ratio' or 'Golden Section'.

It is believed this ratio can be represented by the number known as phi 1.618033988....., or ratios approximating to this number such as,

$3/2$  ,  $5/3$  ,  $8/5$  ,  $13/8$  ,  $21/13$  and so on.

This proportion system was rigorously employed in the design of ancient Greek and Roman Architecture.

Some Architects today base their design on this system, whereas others employ it instinctively by eye.

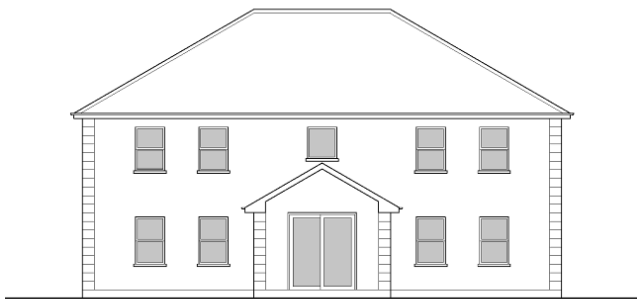
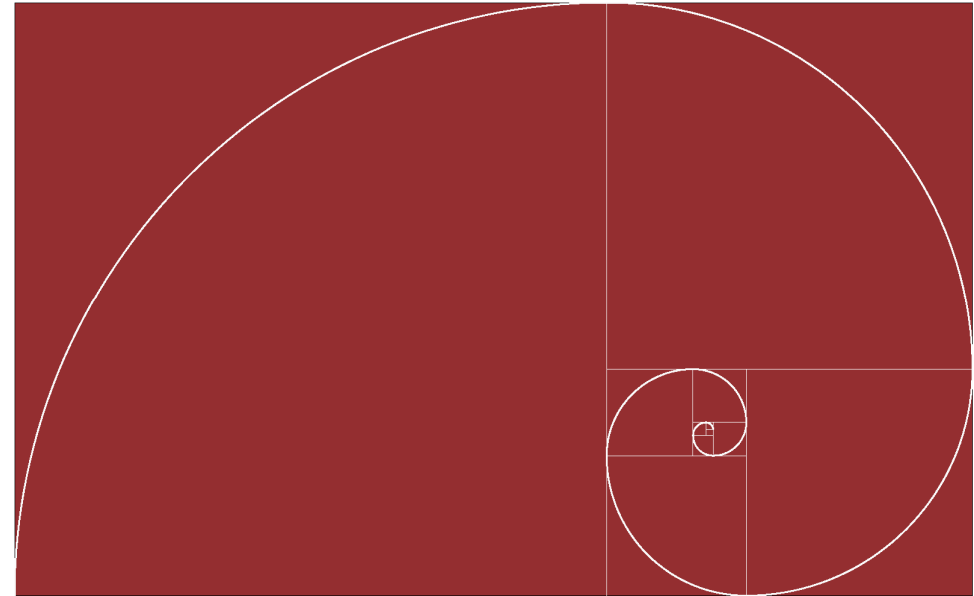

**X**

Most of the finer Neo-Classical Country houses take their design influence from Palladio and his Palladian Mansions and Farm house, all designed with the 'Golden Section/Ratio' in mind, however many of the Mock Classical houses built in the recent past appear to be designed and constructed with little regard to good proportion.



**X**

Example of poorly proportioned house.

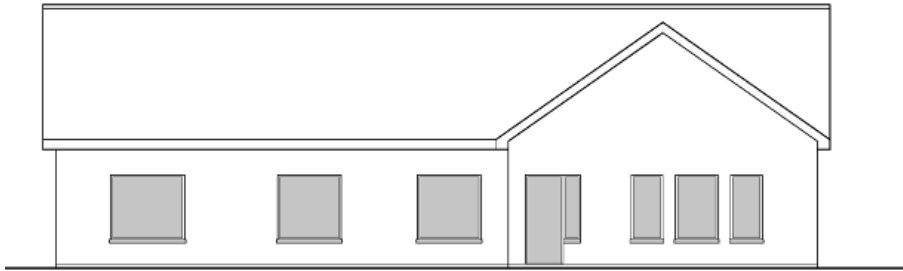

X

Typical bungalow, while modest in scale, poorly proportioned form, irregular sized window opes.

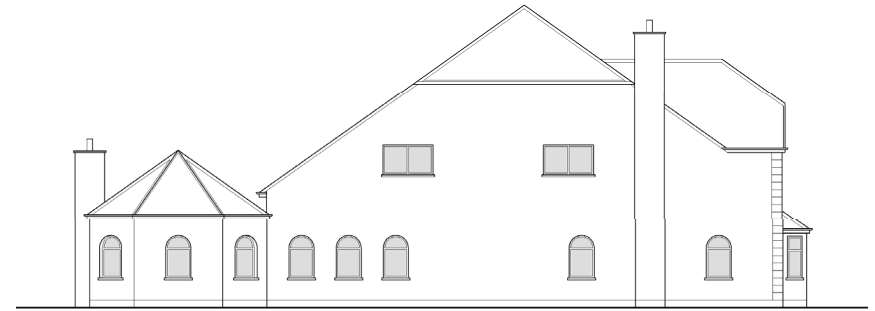

X

Side elevation of typical dormer bungalow, over scaled, all elements out of proportion with each other.

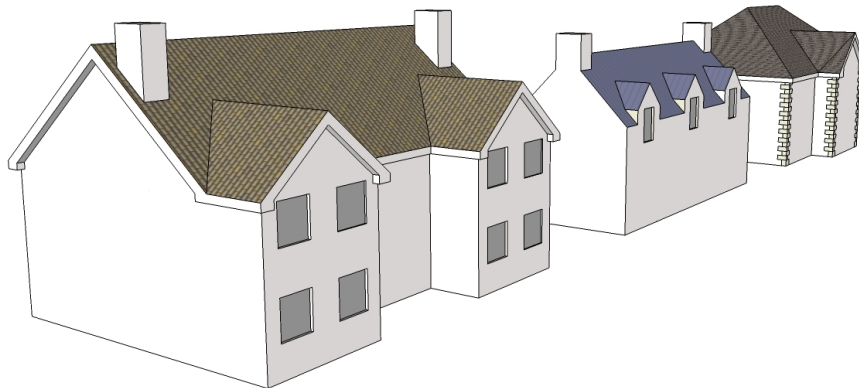

X

Comparison of three different house types with each other.

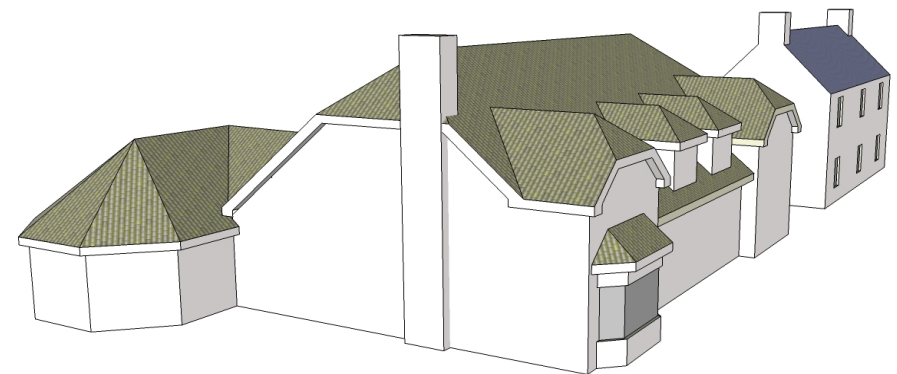

X

The above illustration demonstrates how the scale and proportion of a modern day dormer bungalow compares to the more elegantly scaled and proportioned two storey traditional farm house.





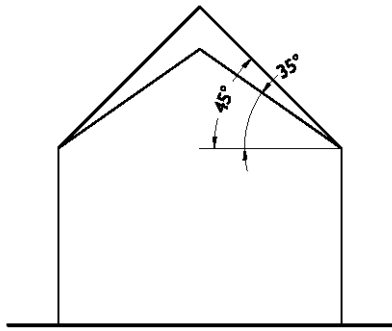

### ✓ ROOF PITCHES

Traditional roof pitches generally range from 35 to 45 degrees

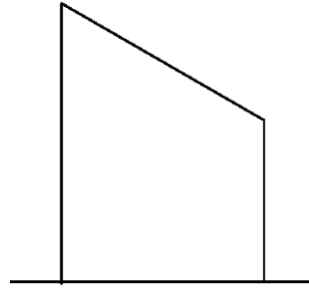

### ✓ MONO PITCH ROOFS

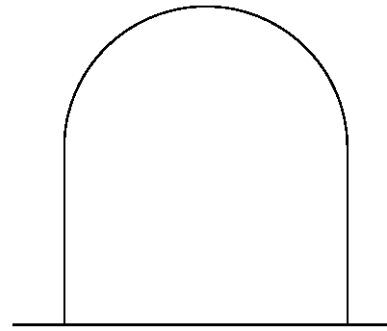

### ✓ DOME OR CURVED ROOF

Simple barrel vaulted roofs can provide a very strong identifiable building form echoing the agricultural shed/barn.

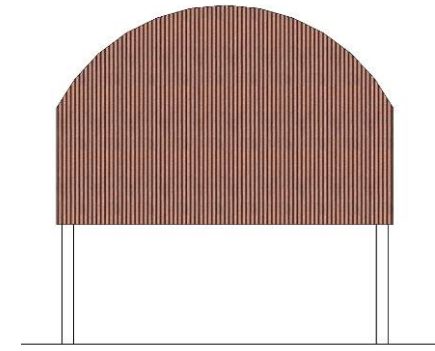

### ✓ AGRICULTURAL ROOF PROFILES

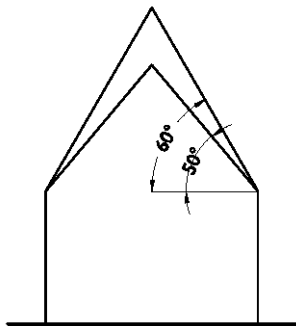

### ✗ AVOID

Very steep pitches.

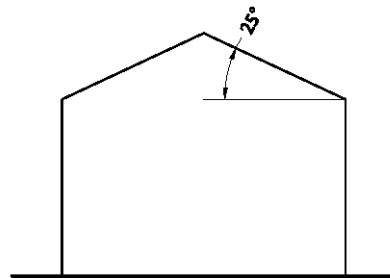

### ✗ AVOID

Shallow pitches.

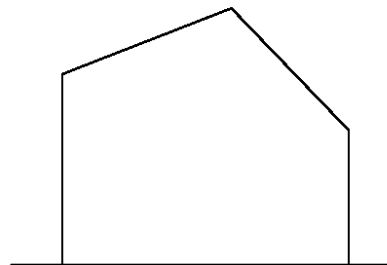

### ✗ AVOID

Unequal pitches.

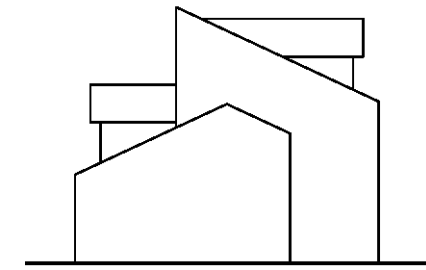

### ✗ AVOID

Complex and varying roof pitches.



✓ TRADITIONAL EAVES AND GUTTER

Note no projecting fascia or soffit, simple clean lines, less maintenance.



✓ RAINWATER PIPES AND GUTTERS

Power coated aluminum or metal gutters and downpipes with simple profile and bracketing



✓ EAVES

Natural and manmade slates can be supplied with a metal edge profile to achieve a very simple, clean line detail to the gable end.



✓ EAVES

Traditional simple gable detail.

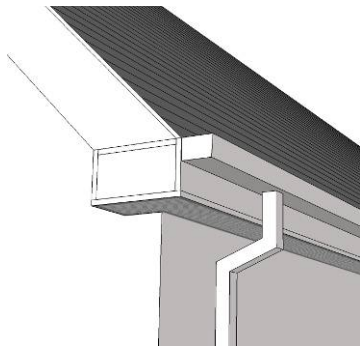

✗ AVOID

Oversized and clumsy boxed fascia and soffit details.



✗ AVOID

Oversized and clumsy boxed fascia and soffit details.



✗ AVOID

Synthetic solutions which attempt to replicate natural materials in colour and texture.



✗ AVOID

Example of oversized boxed fascia and soffit detail.



✓ NATURAL SLATES

Natural slates would have been sourced locally, today there are many sources and varieties. Generally, blue/black, dark grey or dark brown slates acceptable.



✓ BANGOR BLUE NATURAL SLATES

Popular natural slate.



✓ MAN MADE SLATE

Synthetic man made slate with profiled/textured edge to simulate natural slate. Generally acceptable in colours, blue, black or grey.



✓ MAN MADE SLATE

Synthetic man made slate with smooth finish. Generally acceptable in colours, blue/ black, dark grey or dark brown. Assurance should be sought from the manufacturer/supplier on colour retention.



✗ AVOID

Oversized and clumsy profiled roof tiles.

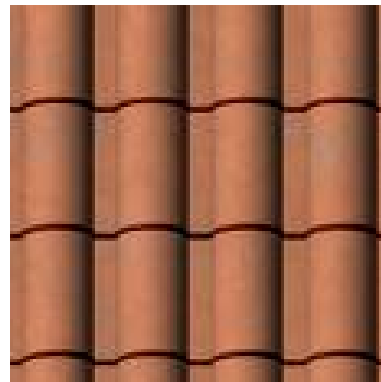

✗ AVOID

Terracotta continental type roof tiles, these are considered not appropriated in an Irish context.



✗ AVOID

Bright and out of context colours.

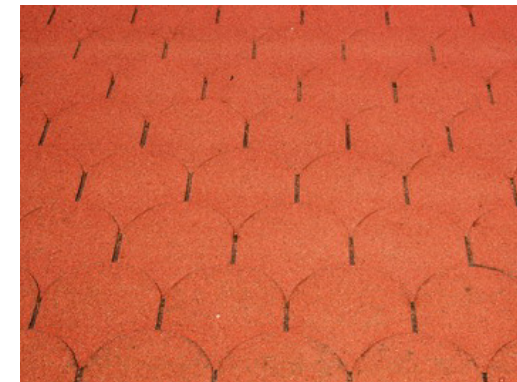

✗ AVOID

Odd shaped profiles.



✓ ZINC STANDING SEAM ROOF

Zinc standing seam roof can be supplied with A pre-weathered finish, grey colour.

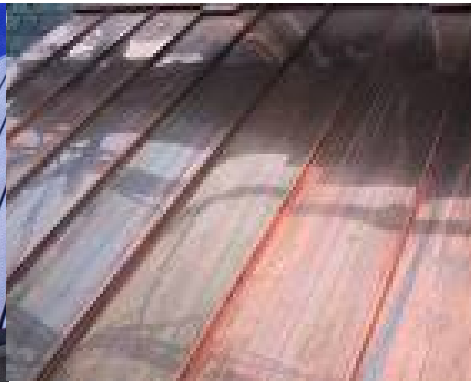

✓ COPPER

Copper was traditionally used for ridges, dormers and other features. Can be supplied in sheet from to achieve standing seam finish.



✓ WEATHERED COPPER.

Copper will weather/go green over time. It can also be supplied with a pre-weathered, green finish.

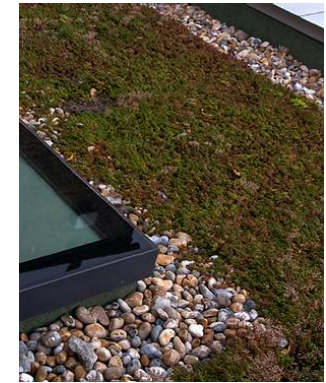

✓ GREEN ROOF COVERING

The roof covering aids water attenuation by absorbing the rain fall and also acts as an insulant.



✓ TRADITIONAL STOREY & HALF DORMER

Simple form, vertical emphasis windows, no boxed fascia or soffit.

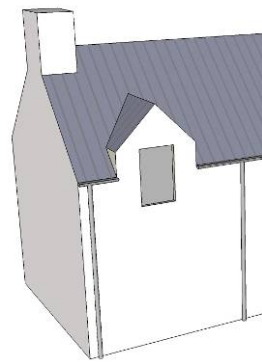

✓ TRADITIONAL STOREY & HALF DORMER



✓ DORMERS

Contemporary interpretation of traditional storey and a half dormer.



✓ DORMERS

Contemporary interpretation.

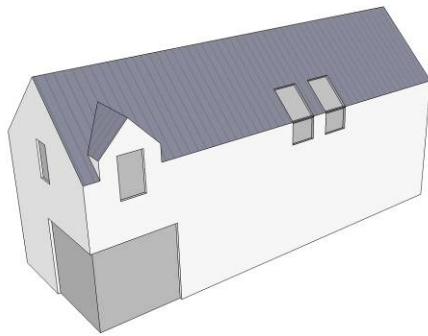

✓ ROOFLIGHTS

There are many types, sizes and opening arrangement of roof lights available on the market. The above example shows a part vertical and part roof slope roof light, this can be a good alternative to a dormer.



✓ ROOFLIGHTS

Apex roof lights

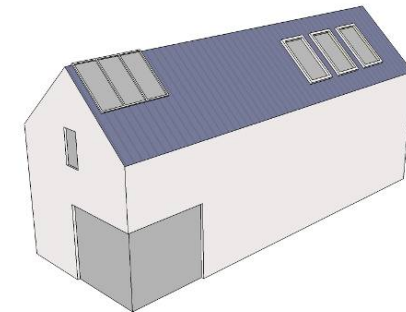

✓ ROOFLIGHTS

Apex roof lights can provide great light penetration to the centre of a roof, and can be used to assist with passive solar gain. Roof lights should be carefully arranged and placed on a roof. Grouping of roof lights together can be affective.



**X AVOID**

Proliferation of dormers, misaligned and poorly located on roof. Roof elevation too prominent.



**X AVOID**

The use of plastic cladding systems.



**X AVOID**

The use of plastic cladding systems, tries to replicate timber cladding unsuccessfully.



**X AVOID.**

Incompatibility of materials transition between wall and dormer uncomfortable.

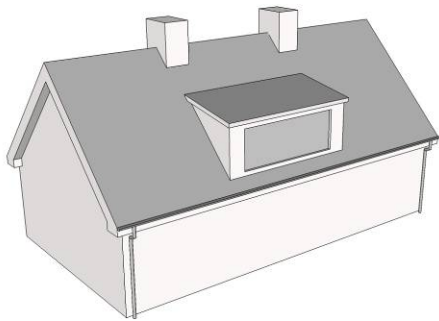

**X AVOID**

Large format dormers with shallow pitch or flat roofs.

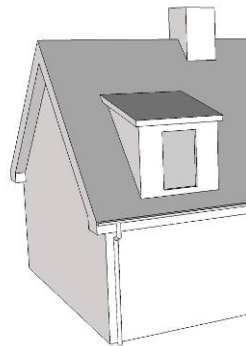

**X AVOID**

Flat roof to dormer, clumsy form.



**X AVOID**

Poorly proportioned dormer and proliferation of roof lights.

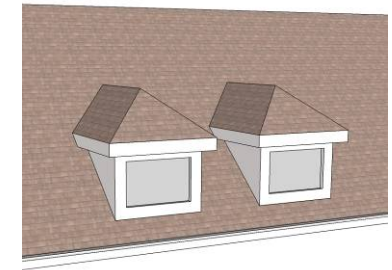

**X AVOID**

Hipped dormers and poorly sized proportions and window opens.

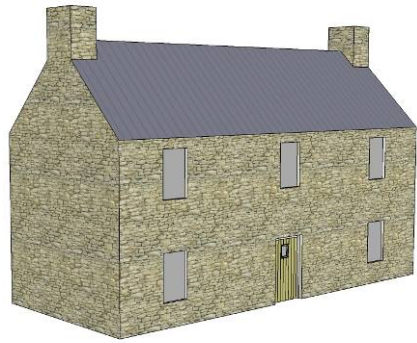

✓ STONE FINISHES

Within the county there is a long well established tradition of stone buildings and houses. In these instances the building are constructed wholly using local natural stone.

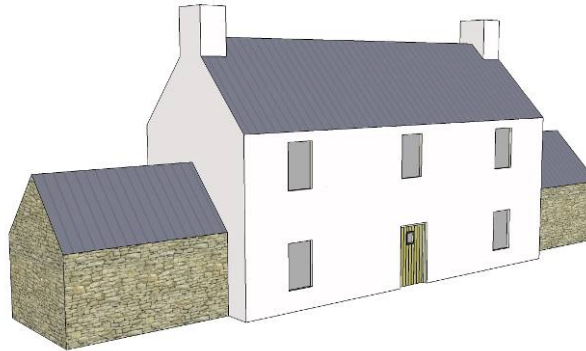

✓ STONE FINISHES

Stone side wings/annexes, it is important that the stone is used on the full 3D element and not applied to the front elevation only.

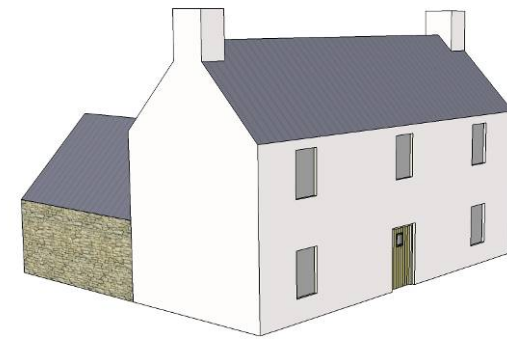

✓ STONE FINISHES

The rear extension finished on all 3 faces with stone, the integrity of the element is maintained



✗ AVOID

Using the stone as purely a facing on one elevation. Viewed from the gable end the integrity of the stone finish undermined.



✓ STONE FINISHES

The main building and all elements finished in stone.



✗ AVOID

Use of stone inconsistent, clearly used as a facing, chimneys clad separately.



### ✓ STONE FINISHES

Within the county there is a long well established tradition of stone buildings and houses. In these instances the building are constructed wholly using local natural stone.



### ✓ STONE FINISHES

It is important that the stone is used on the full three dimensional element and not applied to the front elevation only.



### ✓ STONE FINISHES

Natural stone used throughout.



### ✗ AVOID

Non local stone, poor coursing.



### ✗ AVOID

Avoid the use of stone as a veneer, it needs to appear as a constructional element. To achieve this the detailing at opes and corners need careful consideration.



### ✗ AVOID

Example of poor stone selection, sizing, coursing, quoin and window surround detailing.

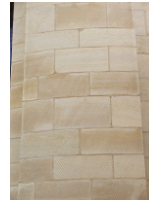
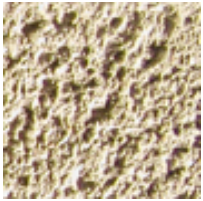

### ✓ WALL FINISHES, RENDERS:

In general nap plaster or dash finishes are acceptable. In addition Pigmented renders are also acceptable, these come in a number of colours and textured finishes.

### ✓ NATURAL STONE FINISHES.

Well selected natural stone is acceptable; in general a sample of the proposed stone will be required for approval prior to commencement of the construction. Smooth facing stone is also acceptable.

### ✓ METAL CLADDING

Cladding such as copper or zinc are also acceptable where appropriately used and detailed.



### ✓ BRICK FINISHES.

In general brick is not traditional throughout the County; however there are a number of pockets such as Donaghpatrick where a very fine orange/red brick has been used to build a number of houses. There are a wide variety of brick, colours, textures and finishes available on the market, many of which would not be suitable in a rural context. If considering brick as a finish an applicant should discuss this preference with the planners at pre-planning stage. Samples of the brick being proposed will need to be provided for approval. Brick as a finish will be only considered in areas of the county where a long established tradition of brick as a finish exists.

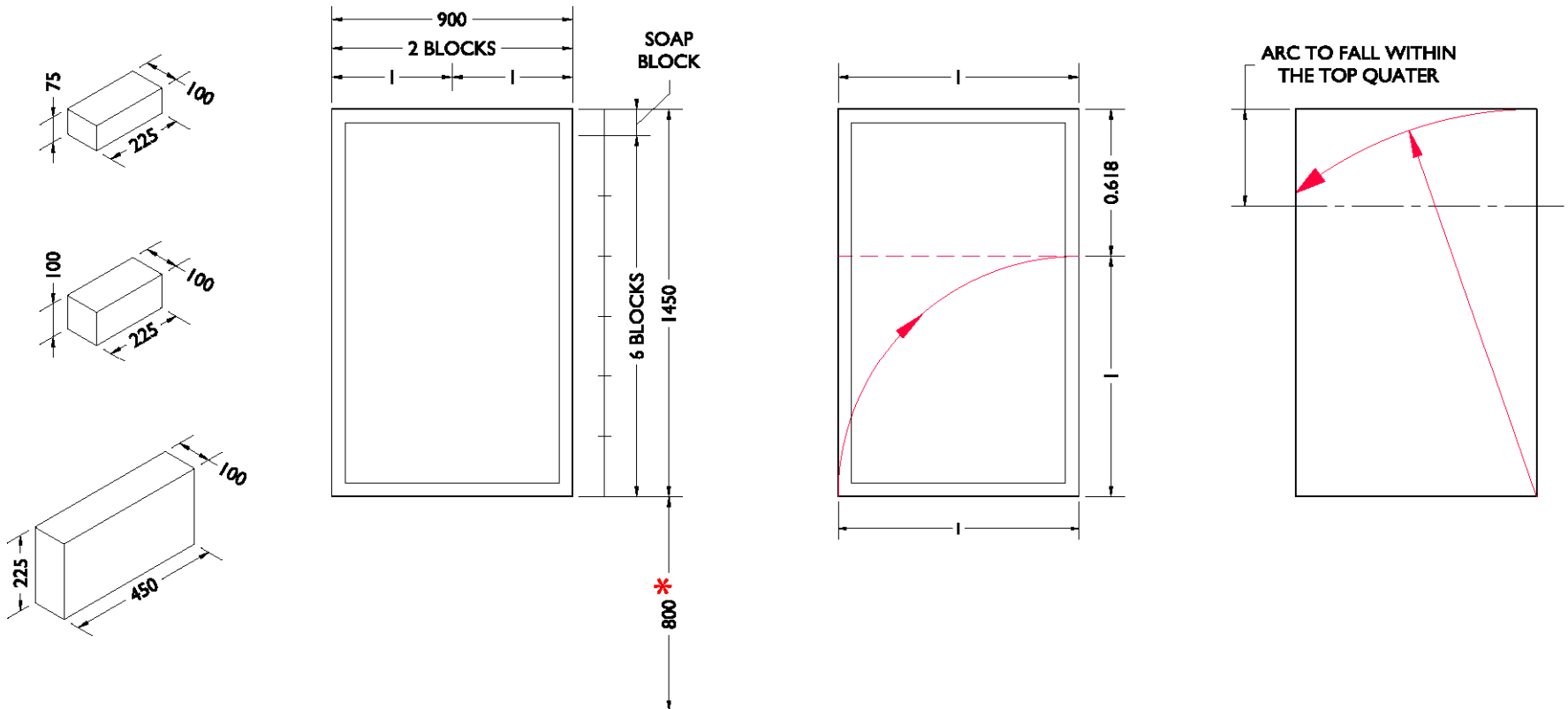

**DOOR & WINDOW OPES**

Generally the size of window and door opes are determined by block and brick sizes.

**SETTING OUT OF OPE**

The width and height of the ope can be set out using these sizes and applying the proportioning system described earlier. The above example of a 900mm wide x 1450mm high ope which matches the proportions of the golden section allow for standard block sizes.

**PROPORTION**

The golden section outlines a proportion ratio of 1 to 1.618

**PROPORTION**

Simple rule check, arc to fall within top quarter of the ope.

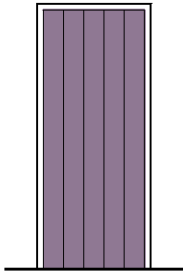

✓ PREFERRED DOORS  
DESIGNS & TYPES

Simple painted timber planked door.

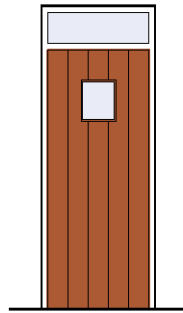

✓ PREFERRED DOOR

Timber planked door with glazed vision panel and fan light over.

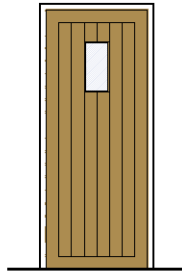

✓ PREFERRED DOOR

Timber framed tongue and groove door with rectangular vision panel.

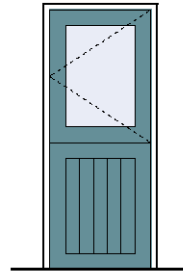

✓ PREFERRED DOOR

Traditional timber half door, With glazed, opening top section.

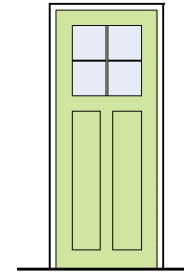

✓ PREFERRED DOOR

Panel door, vertical emphasis with glazed top panel.

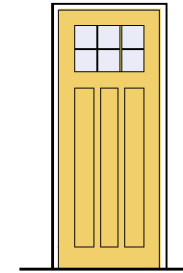

✓ PREFERRED DOOR

Panel door, vertical emphasis with glazed top panel.

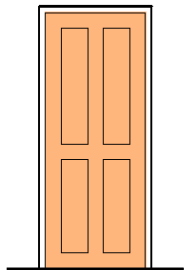

✓ PREFERRED DOORS

Solid timber panelled door.

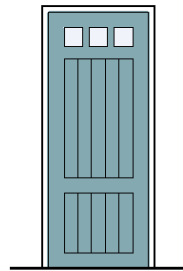

✓ PREFERRED DOOR

Variant on the timber framed tongue and groove door.

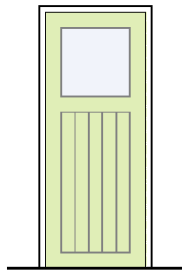

✓ PREFERRED DOOR

Timber framed tongue and groove door with larger glazed section.

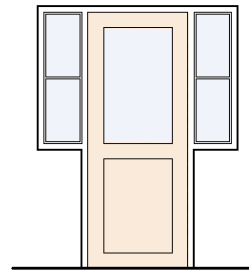

✓ PREFERRED DOOR

Panel door with large glazed section and side lights.

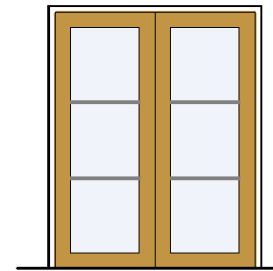

✓ PREFERRED DOOR

Glazed double doors.

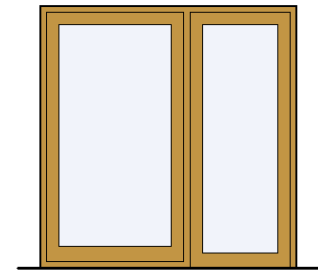

✓ PREFERRED DOOR

Larger framed slider or hinged doors for access to patios and external spaces

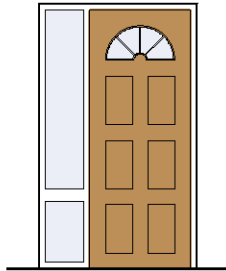

**X** DOOR DESIGNS & TYPES TO BE AVOIDED.

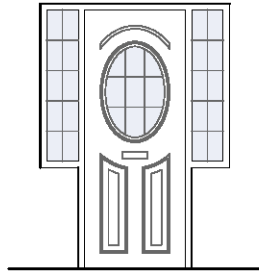

**X** AVOID

Mock period door in white plastic, too fussy and detailed to imitate wood look.

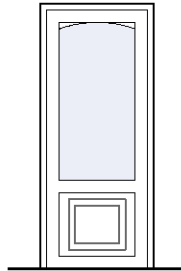

**X** AVOID

White plastic, badly proportioned, over elaborate infill.

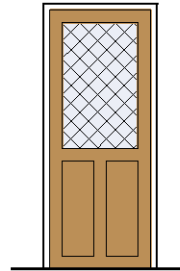

**X** AVOID

Mock period door, confused styles.

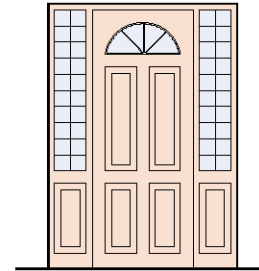

**X** AVOID

Mock Georgian door.

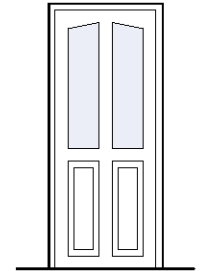

**X** AVOID

White plastic door detailed as if made from timber.

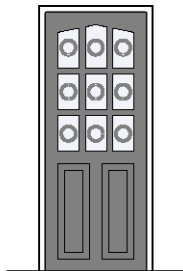

**X** AVOID

Over ornate and elaborate glazing

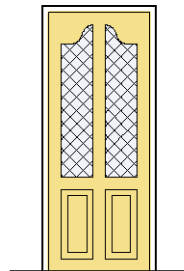

**X** AVOID

Over ornate and elaborate glazing

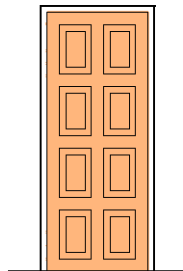

**X** AVOID

Poorly sized panels

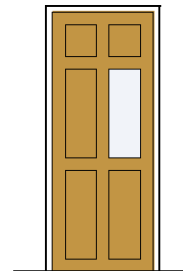

**X** AVOID

Poorly positioned glazed panel.

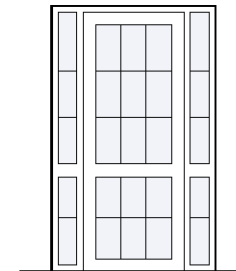

**X** AVOID

Mock Georgian door in white plastic.

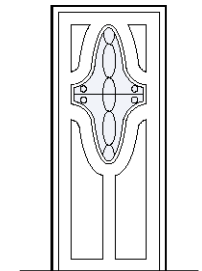

**X** AVOID

Overly ornate door in white plastic.

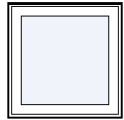

✓ PREFERRED WINDOW DESIGNS , TYPES & SIZES

Square.

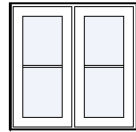

✓ PREFERRED WINDOW

Two equal opening sections  
Vertical emphasis.

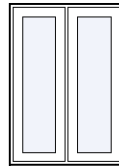

✓ PREFERRED WINDOW

Two equal opening sections  
Vertical emphasis.

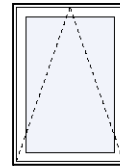

✓ PREFERRED WINDOW

Top hung, good proportion,  
vertical emphasis.

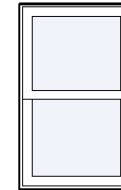

✓ PREFERRED WINDOW

Two equal, opening sections,  
vertical emphasis,  
unchanged.

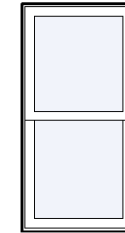

✓ PREFERRED WINDOW

Tall rectangular window.

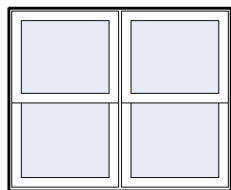

✓ PREFERRED WINDOW DESIGNS , TYPES & SIZES

Window broken up into four equal squares.

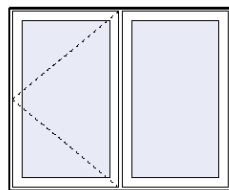

✓ PREFERRED WINDOW

Horizontal ope, however vertical emphasis maintained with opening sections.

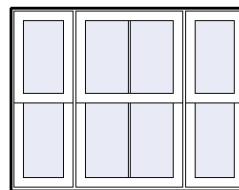

✓ PREFERRED WINDOW

Horizontal ope, however vertical emphasis maintained with opening sections.

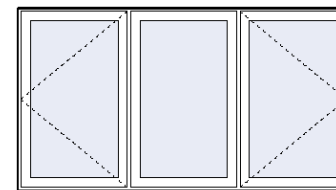

✓ PREFERRED WINDOW

Horizontal ope, however vertical emphasis maintained with 3 equal opening sections

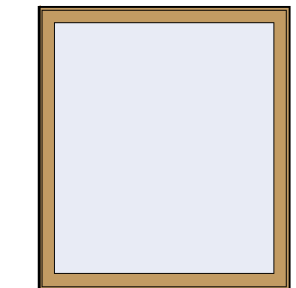

✓ PREFERRED WINDOW

Large floor to ceiling window

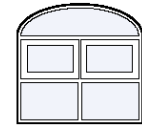
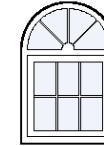
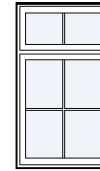
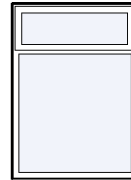
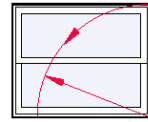
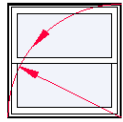

**X** WINDOW DESIGNS,  
TYPES & SIZES TO BE  
AVOIDED.

**X** AVOID

**X** AVOID

**X** AVOID

**X** AVOID

**X** AVOID

Poor proportion and sub  
division.

Poor sub division, top  
Light too high.

Poor sub division, top  
Light too high.

Mock Georgian.

Poor proportion and subdivision

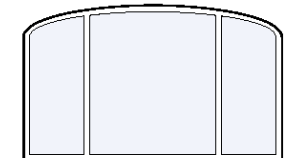
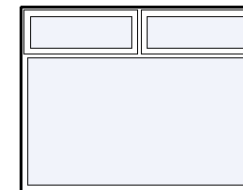
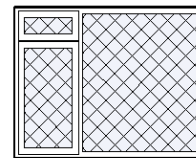
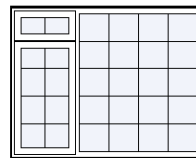
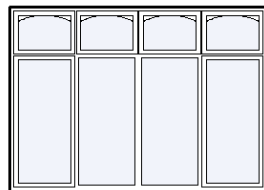
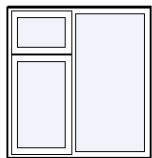

**X** AVOID

**X** AVOID

**X** AVOID

**X** AVOID

**X** AVOID

**X** AVOID

Unequal panes

Over elaborate break up

Horizontal emphasis, mock  
Georgian, break up  
Effect, white plastic

Mock Period , break up  
Effect.

Horizontal emphasis,  
Top Lights too small.

Poor shape and sub-division.

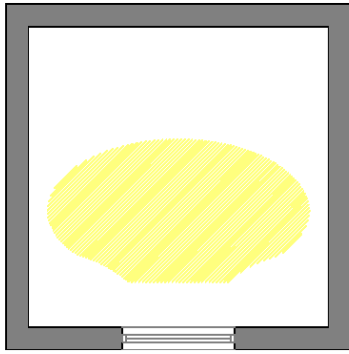

PLAN OF CONVENTIONAL WINDOW

Level of light penetration into the room.

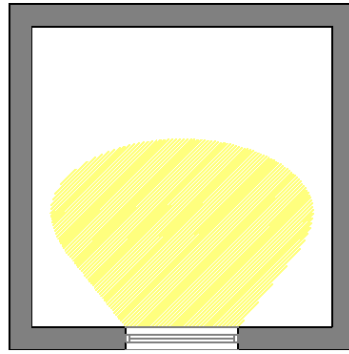

PLAN OF WINDOW TAKEN TO THE FLOOR

Greater light penetration, light reflects of the floor.

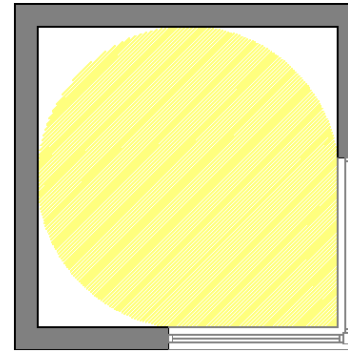

✓ CORNER WINDOW

Corner windows taken to the floor achieves greater light penetration and distribution within the room.

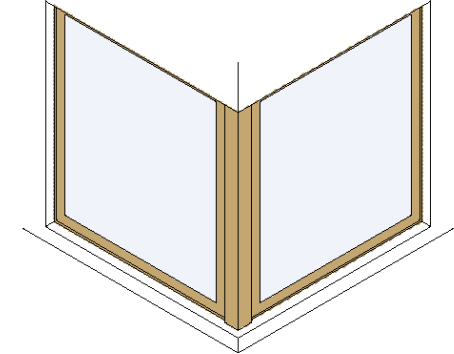

✓ CORNER WINDOW

Like other windows and opes, corner windows should be sized and proportioned correctly

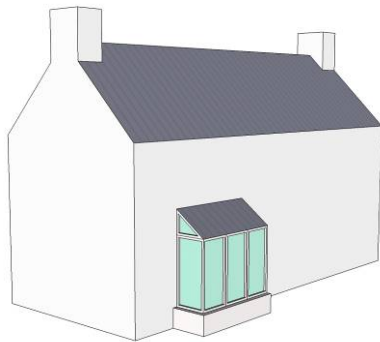

✓ BAY WINDOW

Well proportioned and detailed bay windows will generally be acceptable.

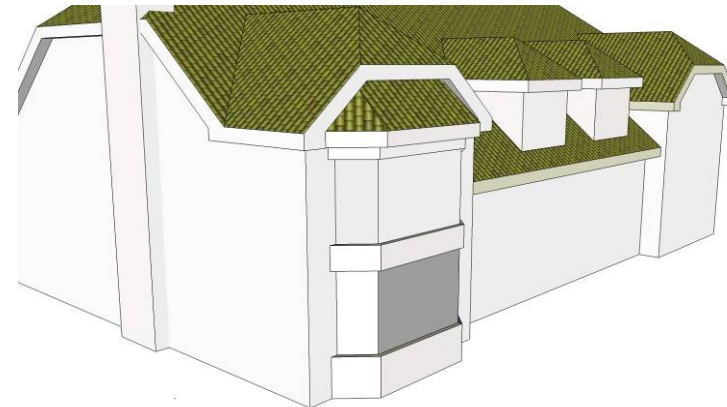

✗ AVOID

Two storey bay windows to the front elevation.

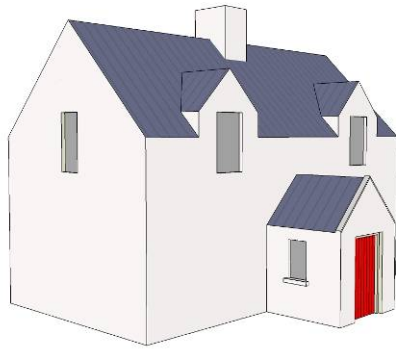

✓ PORCH

Simple apex roof form, no large or clumsy over hanging eaves or soffits.



✓ PORCH

Mono pitched porch with door to the side.



✓ PORCH

Simple apex roof form with door to side, the door to the side helps to protect against the prevailing winds.



✓ PORCH

Timber framed apex roof, glazed porch

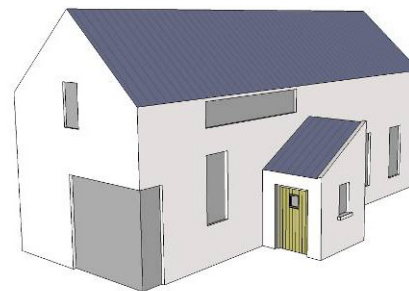

✓ PORCH

Mono pitched porch form with the door to the side.



✓ PORCH

Mono pitched porch, door to the side and large corner window.



✓ PORCH

Simple traditional porch,



✓ PORCH

Most traditional/vernacular houses have no porches as the front elevations are in plane, with no projections, the main door positioned centrally.



✓ PORCH

Simple traditional porch,

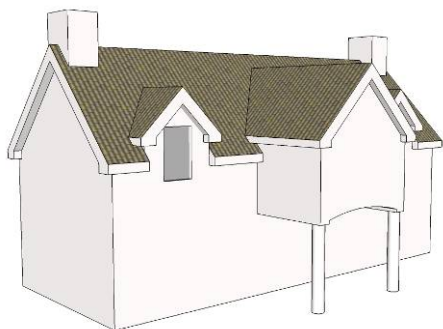

✗ AVOID

Setting a projecting element up on stilts/ columns to form a porch or carport, can look clumsy and complicates the front elevation.



✗ AVOID

Mock classical pedimented porticos.

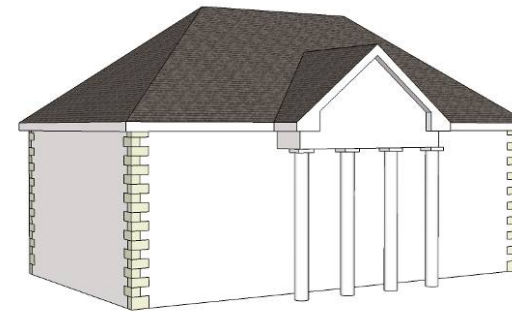

✗ AVOID

Mock classical pedimented porticos, most built examples are incorrectly proportioned and use plastic columns which do not respect the ancient classical orders, Doric, Ionic, Corinthian and Composite.

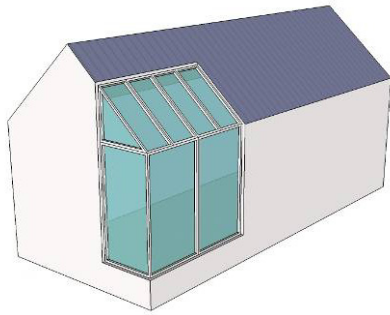

✓ **SUN ROOM**

Sun room integrated within the overall volume/form of the building.

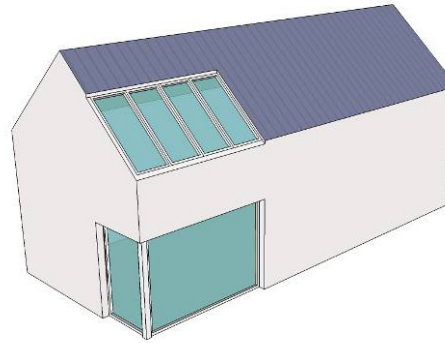

✓ **SUN ROOM**

Sun room integrated within the overall volume/form of the building, by the use of large corner glazing and purpose built roof light over.

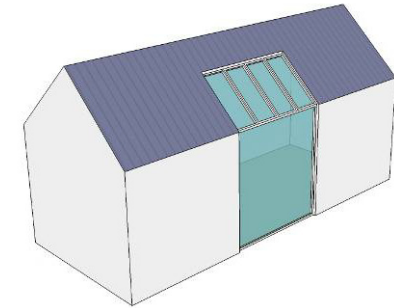

✓ **SUN ROOM**

Sun room located centrally within the building form, this approach can provide many benefits in relation to passive solar gain to the surrounding rooms.

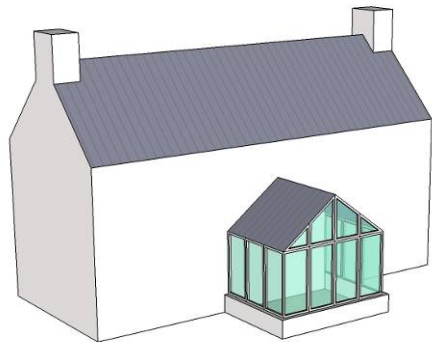

✓ **CONSERVATORY/SUN ROOM**

Simple apex sunroom/conservatory form attached to the building.

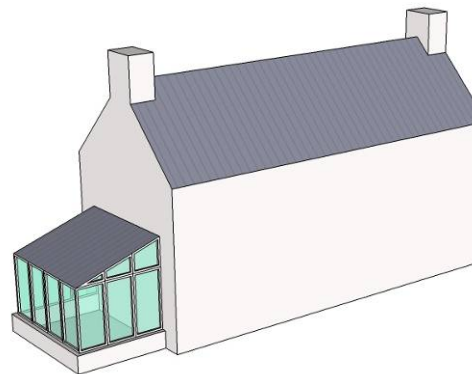

✓ **CONSERVATORY/SUN ROOM**

Lean to conservatory form.

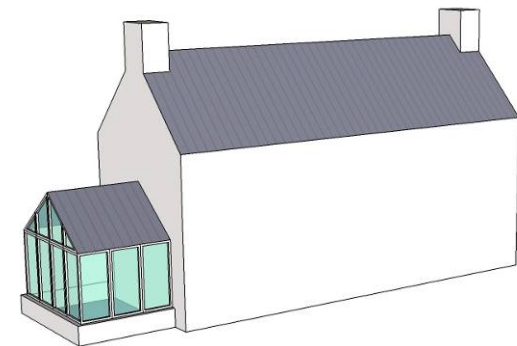

✓ **CONSERVATORY/SUN ROOM**

Simple apex sunroom/conservatory form to the gable end.

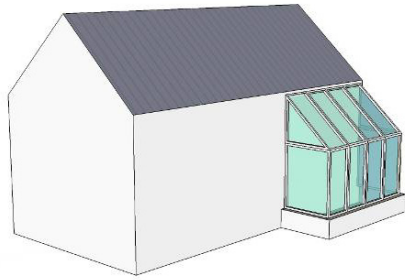

✓ **CONSERVATORY/SUN ROOM**

Storey and half conservatory attached and integrated with building form.



✓ Corner glazing incorporated within the overall form to the south element of the building to create a sun trap/sun room.



✓ Glazing incorporated within the overall form to create sun trap.



✓ Corner glazing incorporated within the overall form to the south element of the building to create a sun trap/ sun room.



✓ Building elements arranged in a courtyard format, to shelter private patio area with large glazed section to create transparency and connection between inside and outside.



✓ Covered transitional space between inside and out.

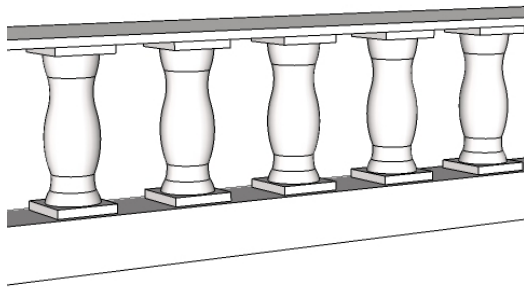

**X** AVOID:

Over elaborate and ornate balustrade detailing to terraces and patio areas.

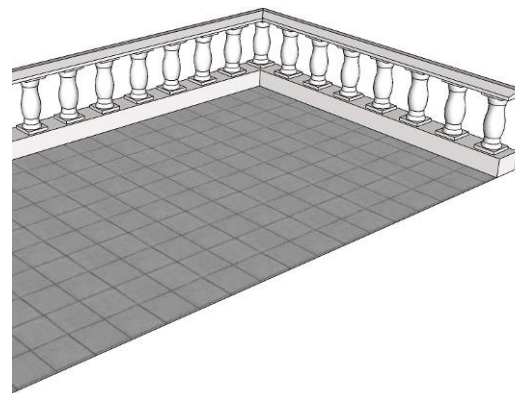

**X** AVOID:

Over elaborate and ornate balustrade detailing to terraces and patio areas.

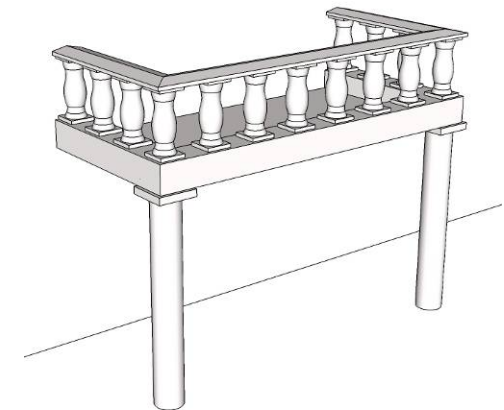

**X** AVOID:

Over dominant and prominent balcony structures. Over elaborate balustrade detailing.

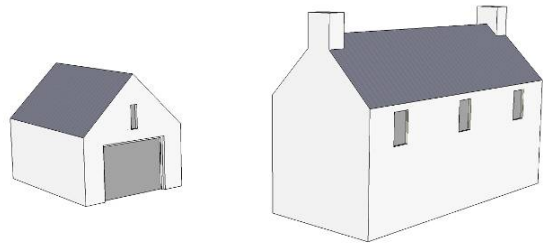

### ✓ DETACHED GARAGE

In general the garage form should reflect the form design and finishes on the main house. The relevant Planning and Development Regulations should be consulted in relation to criteria governing exemptions on garage, stores and sheds within the curtilage of a house.

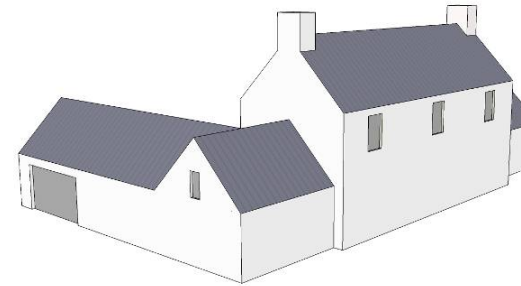

### ✓ ATTACHED GARAGE

The garage structure can be used to create an external enclosure and provide shelter, forming a courtyard or similar external space.



### ✗ AVOID:

Over sized and poorly positioned garage structures which dominate the main house.

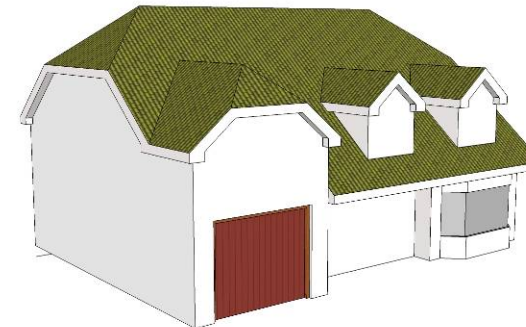

### ✗ AVOID:

Integrated garages which dominate the front elevation of the house.

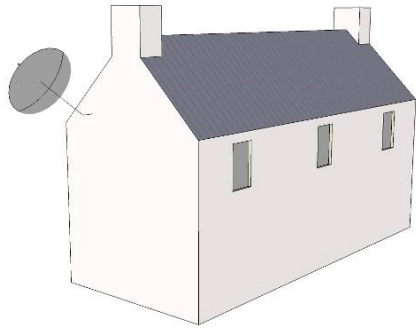

✓ **SATELLITE DISHES:**

A satellite dish up to 1m across and positioned below the top of the roof is exempted development only to the rear or side of the house. The relevant Planning and Development Regulations should be consulted in relation to criteria governing exemption.

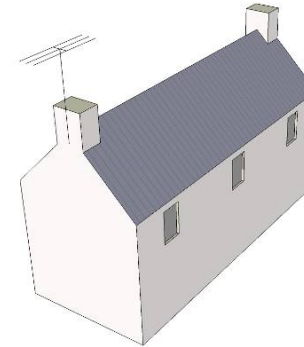

✓ **TV OR RADIO AERIALS:**

A TV or radio aerial is exempted once it does not exceed 6m in height above the roof.

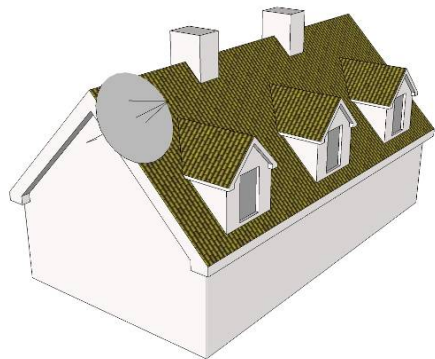

**X AVOID:**

A satellite dish over 1m in diameter or positioned above the top of the roof, or to the front of the dwelling will require planning permission.

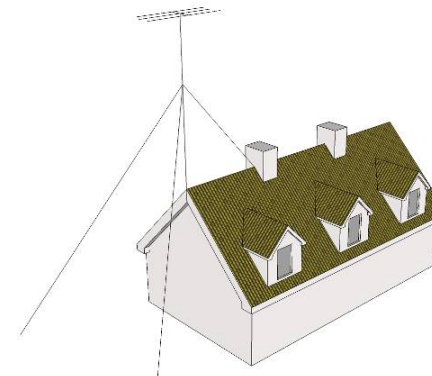

**X AVOID:**

A TV or radio aerial exceeds 6m in height above the roof will require planning permission and should be avoided.





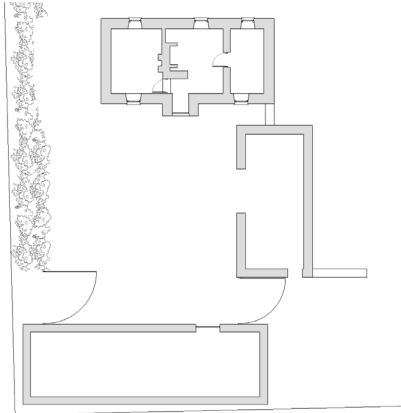

#### TRADITIONAL COTTAGE NEAR KELLS

One of the few remaining examples of the vernacular cottage. White washed/lime rendered walls, strong primary colours to windows and doors and thatched roof. The house is perpendicular to the road, with its gable end wall fronting the edge of the road.

#### COTTAGE AND OUTBUILDINGS.

House and buildings forming simple enclosed courtyard



#### TRADITIONAL COTTAGE

Cottage parallel with the road, simple strong form to porch.

#### COTTAGE

In many instances the traditional thatch was replaced by corrugated metal roofing.



#### TYPICAL FLOOR TRADITIONAL COTTAGE

Single depth rooms, cellular layout.

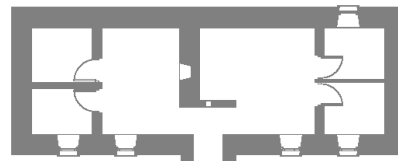

#### EXTENDED COTTAGE PLAN

Larger cottage as farmhouse, with bedrooms either end access via main living areas.



#### COTTAGE SET BACK FROM THE ROAD.



#### COTTAGE ELEVATION

Stong, simple form.



**X** TYPICAL DORMER BUNGALOW

Deep plan, resulting in an incongruous building form, too many elements, excessive scale and poor massing.

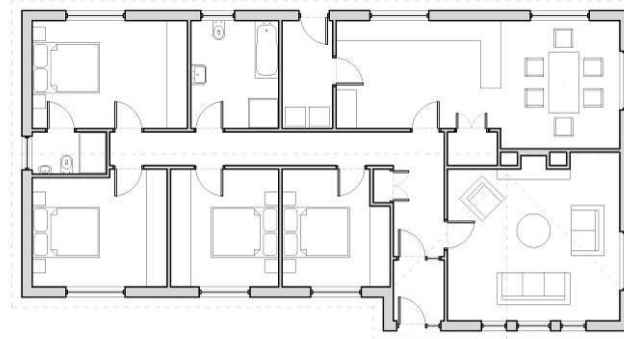

**X** TYPICAL BUNGALOW FLOOR PLAN

Long narrow, dark corridors, building sits as an object on usually ½ to an acre plot. No relationship between internal and external spaces. Building form does not create sheltered open amenity spaces.



**X** TYPICAL DORMER BUNGALOW

Uncomfortable size, scale and massing, poor material selection, mixture of window shapes.

**STOREY AND HALF COTTAGE**

Simple house form with mature planting and grounds.

**STOREY AND HALF HOUSE****MODEST STOREY AND HALF COTTAGE****ESTATE COTTAGES:**

Simple cut stone storey and half cottages.

**STOREY AND HALF DUNSANY****STOREY AND HALF THATCH HOUSE**

This form was common to County Meath and were referred to as Thatched Mansions.



**TWO STOREY FARM HOUSE CULMULLIN**

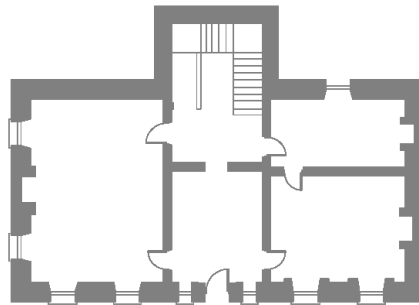

**TYPICAL GROUND FLOOR PLAN**



**RED BRICK TWO STOREY PERIOD HOUSE**



**TYPICAL PERIOD FARM HOUSE**

Typical ground floor plan of two storey farm house.

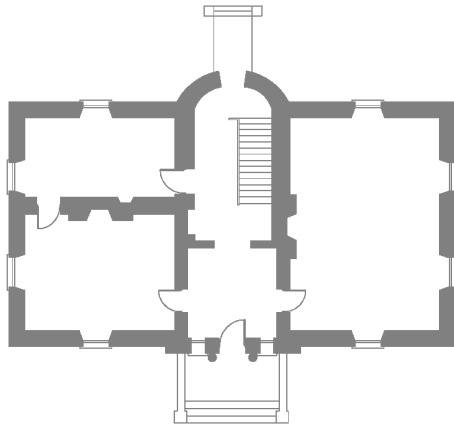

**TYPICAL GROUND FLOOR PLAN**

Typical ground floor plan of two storey farm house.



**MODEST TWO STOREY HOUSE**



**MODEST CLASSICAL PERIOD HOUSE**



**SITE PLAN COUNTRY FARM HOUSE**

Typical Site plan of a two storey farm house and its grounds. Farm and out buildings create a formal courtyard, usually constructed of natural local stone.



3 Storey period house near Duleek



Period farm house



Loughcrew



Site plan of typical country estate house

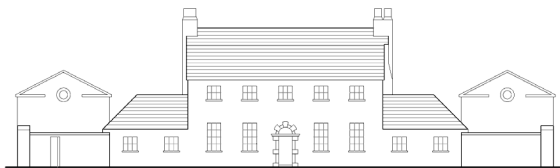

Kilcarty Kilmessan



Elevation of estate house Summerhill

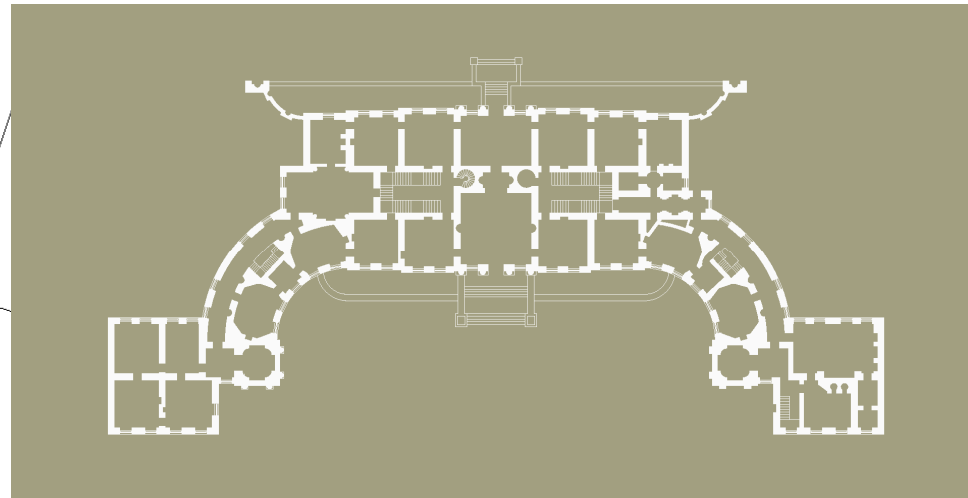

Plan of estate house Summerhill

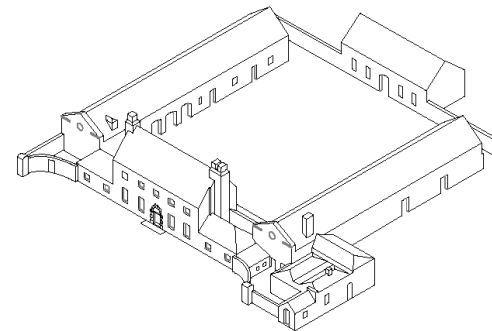

Kilcarty Kilmessan



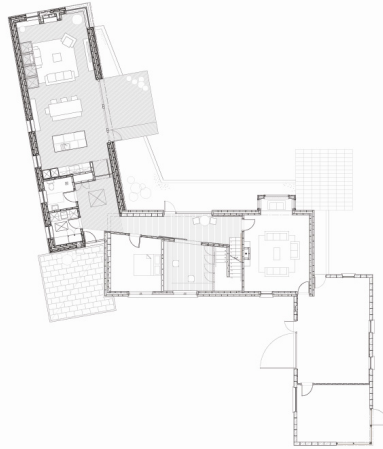

**EXAMPLES OF CONTEMPORARY HOUSES USING THE TRADITIONAL FORM TO GREAT EFFECT.**

Contemporary interpretation of the traditional simple house form. Strong gable form, simple detailing of elements, strong lines and simple colour and material selection.



**EXAMPLES OF CONTEMPORARY USING THE TRADITIONAL FORM TO GREAT EFFECT.**

Contemporary interpretation of the traditional simple house form. Strong gable form, simple detailing of elements, strong lines and simple colour and material selection.



#### EXAMPLES OF CONTEMPORARY EXTENSION TO EXISTING HOUSE.

New elements arrange to form enclosed, sheltered courtyard space with direct access to the main living area. Simple strong form used to great effect.

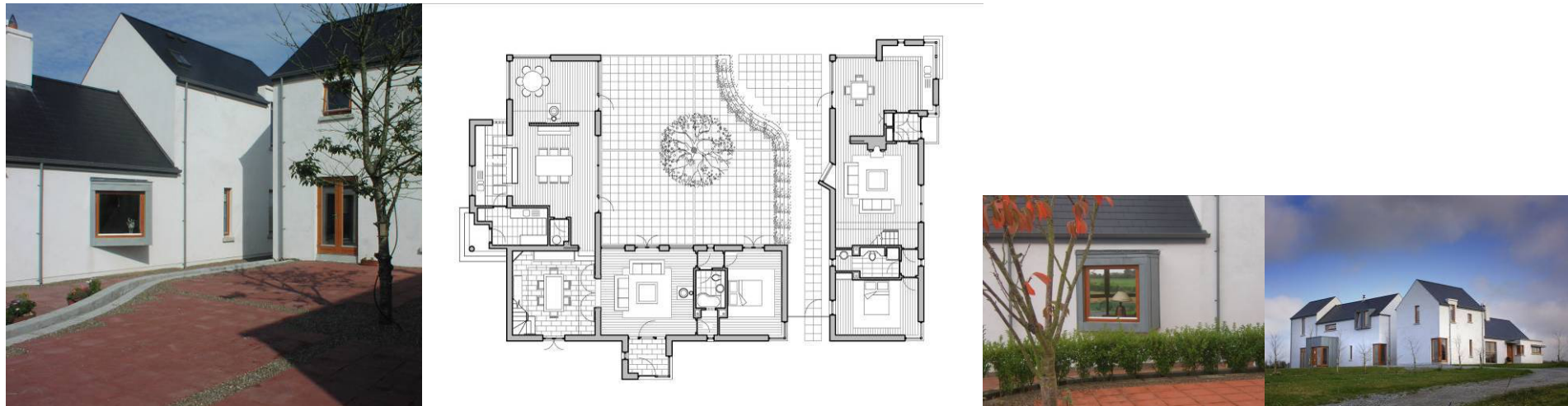

#### TWO HOUSE CLUSTER

Two houses based on traditional form and plan arranged to create a private courtyard. Illustrates a possible approach when building a second house on an existing landholding. Two houses forming a cluster.

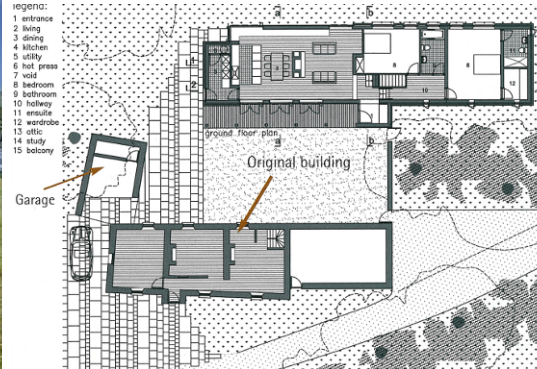

### CONTEMPORARY HOUSE

Stong simple form, barrel vaulted roof form with barrel vault expressed internally.

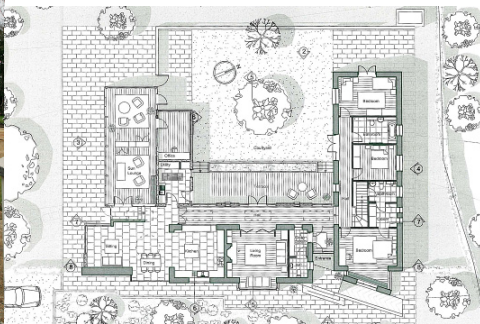

### CONTEMPORARY HOUSE

U shape plan creating private sheltered courtyard space to the rear. Accommodation broken up into a number of distinct forms.

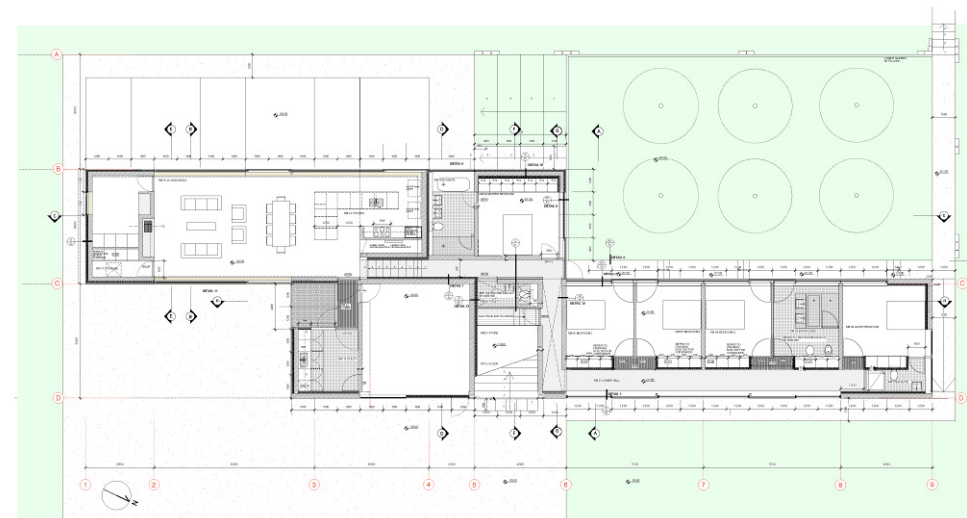
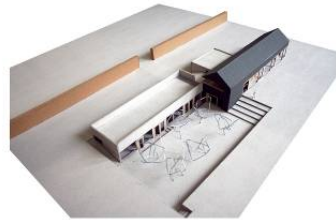
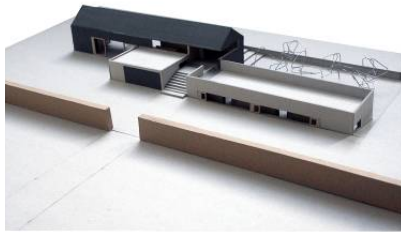

LOWER GROUND FLOOR PLAN

Summerhill, C

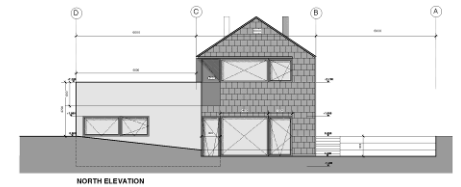

NORTH ELEVATION

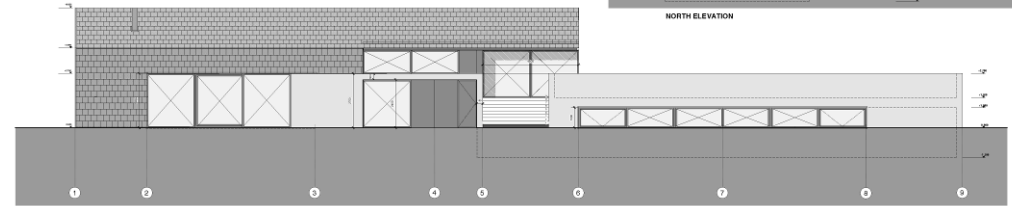

EAST ELEVATION

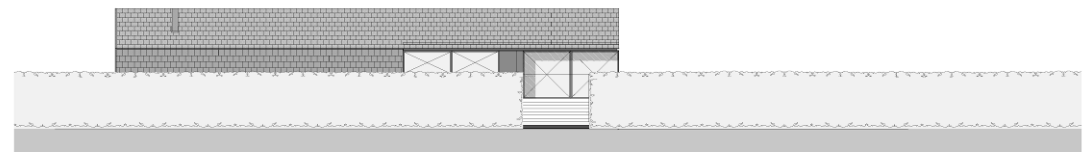

VIEW FROM ROAD AND FRONT PADDOCK

### CONTEMPORARY HOUSE

Utilising simple traditional form, linear arrangement of elements to create a variety of external spaces. Shelter and threshold created by the hedgerow on approach.

**INNOVATIVE DESIGN APPROACHES**

Referencing and assimilation of the relevant aspects of traditional and vernacular building forms provides a wealth of opportunities to create contemporary, modern homes, which respect their setting, context and tradition. The guide actively promotes this approach. It does not, however, exclude one off dwellings which take a more innovative or imaginative approach which may be abstract in reference or organic in nature. Designs of this nature are best developed with the assistance of a trained and experienced design professional, such as a qualified and registered Architect. Any such design proposal should adhere to the basic principles of good design as set out in the guide, such as a relatively simple clear identifiable form, good proportion, scale, siting, orientation, detailing and appropriate use of materials.

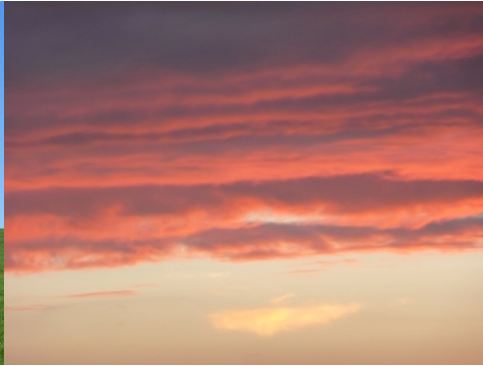

**HEAT PUMPS:**

A heat pump transforms thermal energy at low temperature into thermal energy at a higher temperature which is suitable for heating purposes. Heat pumps are best suited to under floor heating systems where the heat output required is at lower temperatures than that required by conventional radiators.

The heat is extracted by a fluid which is continually circulating in a closed cycle, the fluid constantly undergoing a change of state (evaporation, compression and expansion)

The heat pump draws stored solar energy from its surroundings—the air, water, or the ground and transfers this energy, plus the electrical input energy used to operate the cycle, in the form of heat, into the heating or water heating circulation loop.

In general a heat pump will draw  $\frac{3}{4}$  of its energy from the environment with  $\frac{1}{4}$  being drawn from the domestic electrical supply.

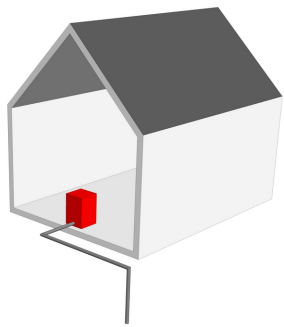

**GEOTHERMAL HEAT PUMP** with bore hole vertical ground collector

Closed loop system utilizing the heat in the ground, bore holes drilled to depths of 40 to 150m, containing one or more pipes. Most effective from a heat collection view point however, drilling can be costly and can run the risk of meeting rock.

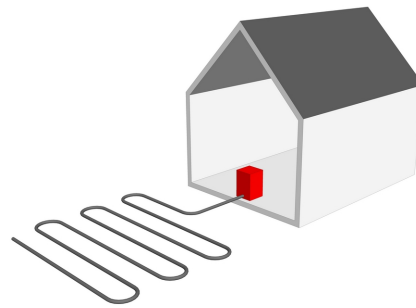

**GEOTHERMAL HEAT PUMP** with horizontal ground collector

Again closed loop system, but pipes laid horizontally in trenches 1 to 2 metres below the surface. Not as efficient as the bore hole option.

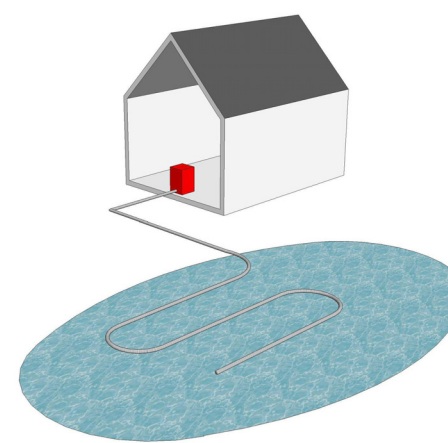

**HEAT PUMP** with collecting from a water source such as a lake or a stream/river.

Capital costs can be associated with the installation can be reduced if a suitable lake or stream are available.

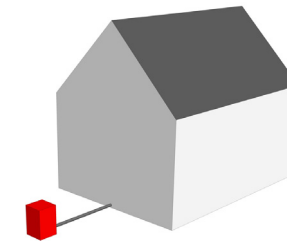

**AIR TO WATER HEAT PUMP.**

A heat pump which takes the heat out of the air moisture. These units are less efficient than the Geothermal heat pumps however capital and installation cost are significantly less, in addition they require very little space, suitable on small sites.

**SOLAR ENERGY :**

County Meath gets between 1300 to 1400 hours of sunlight per year. In designing a house the benefit of this solar energy should be utilised whether by passive solar gain or by active solar collection.

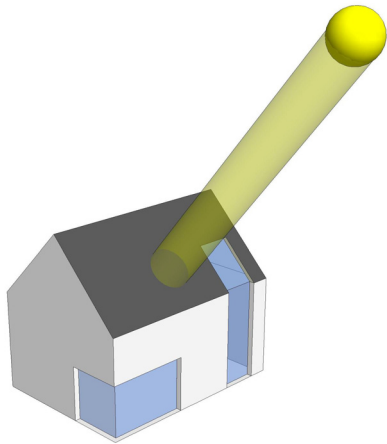
**PASSIVE SOLAR GAIN**

By locating the principal rooms and the larger window opens to the South of the house benefits of solar gain can be enjoyed with the larger openings acting as solar collectors.

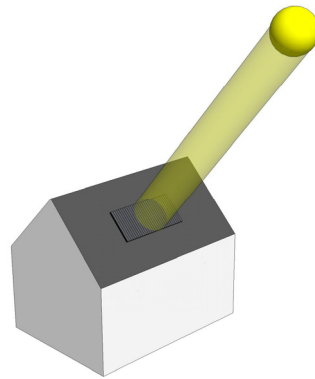
**ROOF MOUNTED SOLAR PANEL**

There are 3 main types of solar panels/collectors, Evacuated tubes, flat panels and Photovoltaic (PV) cells. Evacuated tubes and flat panels are the most common and are generally used for domestic hot water heating, usually backed up by an electric emersion. Whereas Photovoltaic (PV) cells can provide water heating and an electrical input their capital cost is prohibitive, if excess electrical energy generated cannot be sold back to the grid.

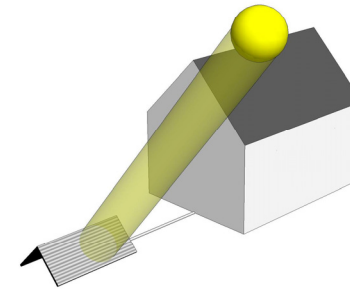
**GROUND MOUNTED SOLAR PANEL**

All of the panels can be mounted at ground level on an 'A' frame structure, but risk damage if not located in a secure part of the site. Solar panels can be cumbersome and unsightly; thought should be given to their location at the early design stage in order to ensure they are properly integrated.

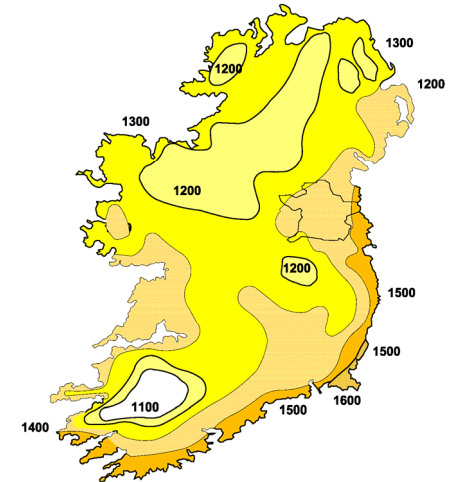
**SUNLIGHT HOURS, MEAN HOURS PER YEAR,**

(Source: Green Design, Sustainable Building for Ireland)

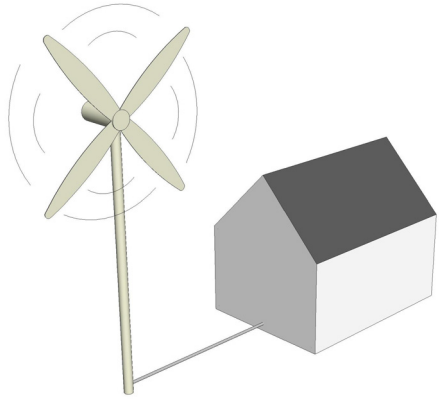
**WIND ENERGY :****WIND TURBINE**

The energy in wind can be captured and converted to provide electricity. Wind energy provides a clean, sustainable solution.

The wind is converted into electricity by the turbine. There are a number of smaller turbines on the market for domestic use.

Most operate on the basis of use it or lose it, However some have battery storage systems

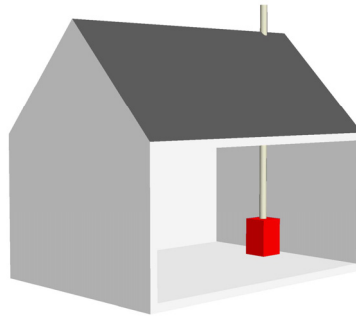
**BIOMASS ENERGY:****WOOD PELLET BOILER**

These burn specially manufactured wood pellets, they can be supplied with direct pellet feed or be fed automatically from a hopper storage area by a belt or conveyor feed.

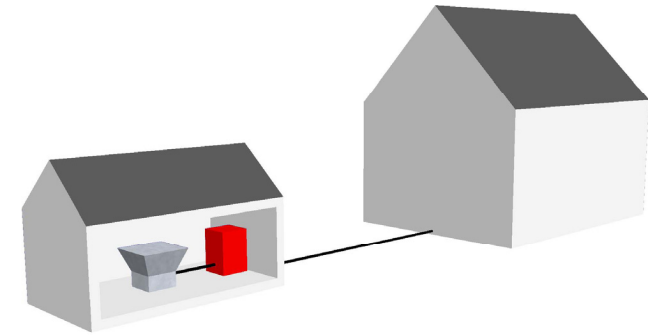
**WOOD PELLET BOILER AND HOPPER SYSTEM**

Larger boilers can have large hopper storage which may require a shed.

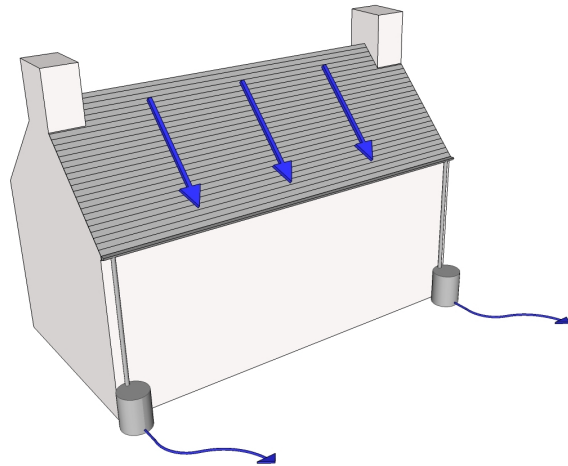
**RAIN WATER COLLECTION :****RAIN WATER COLLECTION**

Rainwater collected from the roof via the rain water gutters and downpipes and collected in water butts/tanks. Water can be used in the garden and for washing of cars etc,

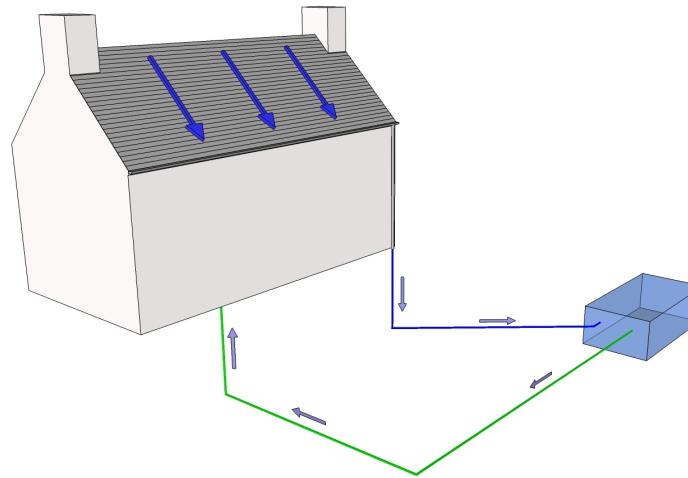
**RAIN WATER COLLECTION:****RAIN WATER COLLECTION**

Rainwater collected from the roof via the rain water gutters and downpipes and collected and stored in a large tank, usually located under the ground. The water is filtered and pumped back into the house for grey water appliances such as WCs and washing machines.

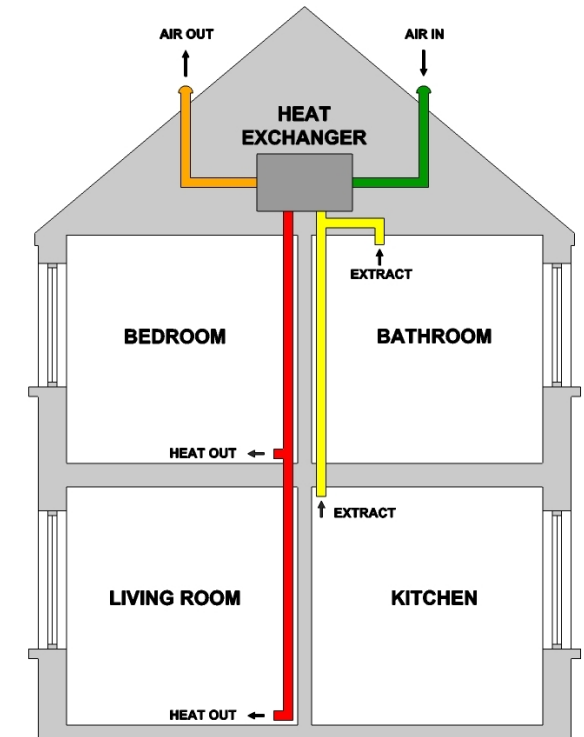
**HEAT RECOVERY SYSTEM:****HEAT RECOVERY SYSTEM**

This is an alternative to passive ventilation. The house being built to a air tightness standard with fresh air from the outside being distributed to the living areas via a heat exchange unit which recycles the heat from the expelled air.

BER :

A **BER** is similar to the energy label for a household electrical appliance like your fridge. The label has a scale of A-G. A-rated homes are the most energy efficient and G the least efficient. From the **1st of January 2009** a BER certificate is compulsory for all homes being sold or rented.

BER assessments performed on new dwellings will also help determine compliance with Part L of the Building Regulations.

BERs should be carried out by specially trained BER assessors, registered by Sustainable Energy Ireland (SEI). A list of BER Assessors is available on the SEI, web site [www.sei.ie](http://www.sei.ie)

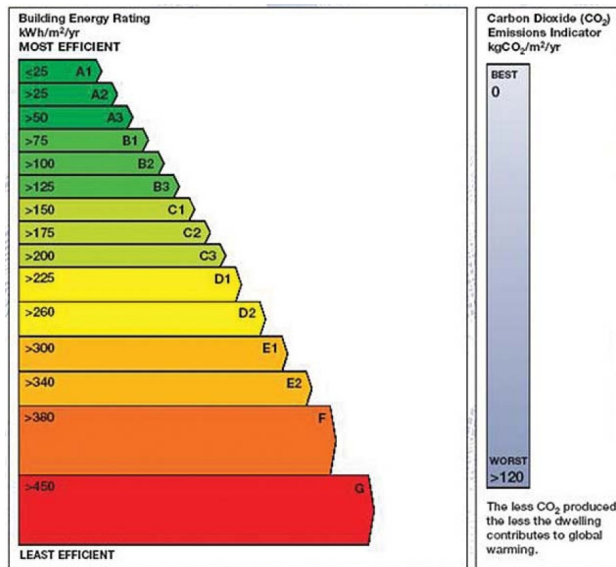

#### BER RATING CERTIFICATE

Rating system for homes and building, grading their energy efficiency and carbon emissions.

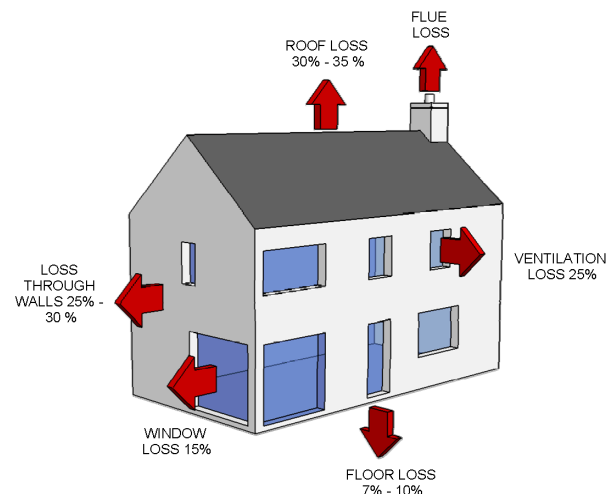

#### AREAS OF HEAT LOSS THROUGH THE FABRIC

Percentage contribution of the various elements to overall heat loss from a house.

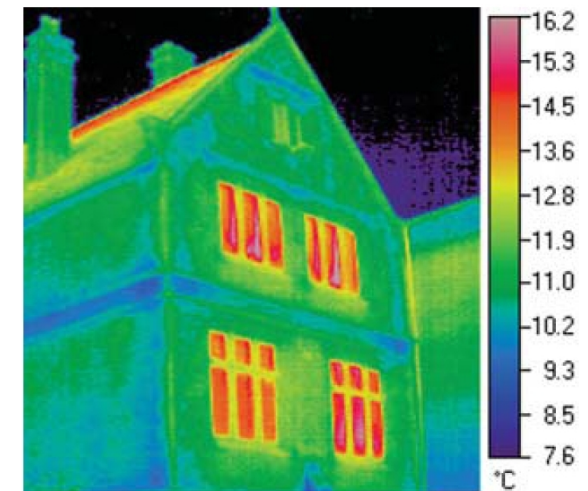

#### THERMAL IMAGE OF A BUILDING SHOWING AREA OF HEAT LOSS

Picture taken with a thermal imaging camera showing the areas of maximum heat loss from the building.

**BUILDING REGULATIONS:**

It is often assumed that a grant of Planning Permission also means that you have complied with the Building Regulations.

This is not the case! Later attempts to achieve compliance may compromise your original planning permission and be very expensive to rectify.

The building regulations should be fully considered at the pre-planning design stage and will result in a warmer, dryer, safer, more accessible and more valuable house in the future.

Aspects of the Regulations to note are:

**Part 'M' - Access for People with Disabilities.**

It is now the law that all new dwellings be accessible and visitable by persons with disabilities. The regulations set down requirements such as level threshold at main entrance door, appropriately sized ground floor visitable toilet at entry level..

The site approach to the main entrance should be no steeper than 1 in 20. Refer to section 1B of Technical Guidance Document-Part 'M'.

**Conservation of Energy Performance of Buildings Regulations & Part L Regulations (Conservation of Fuel & Energy).**

The new 'Heat Energy Rating' (H.E.R) requirements for all new houses will affect the amount of glazing your house accommodates. Elaborate features such as dormers, bay windows & conservatories particularly those positioned at inappropriate locations may lower the H.E.R rating. Whereas correctly oriented larger windows will greatly improve it.

A good HER value will greatly improve your resale value.

Other important regulations on **Fire Safety (Part 'B')** and **Ventilation ( Part 'F')** should also be considered in the development of a design.





**Useful Contacts and Websites:**

- Meath County Council Planning Dept.

Web: [www.meath.ie](http://www.meath.ie)

- Sustainable Energy Ireland.

Web: [www.sei.ie](http://www.sei.ie)

- Department of the Environment, Heritage & Local Government

Web: [www.environ.ie](http://www.environ.ie)

- The Royal Institute of Architects of Ireland

Web: [www.riai.ie](http://www.riai.ie)

- Irish Planning Institute

Web: [www.ipi.ie](http://www.ipi.ie)

**Reference Publications:**

- **Meath County Council Development Plan 2007 – 2013**
- **Planning and Development Guidance Note 1.**

Documentation to be submitted in support of an Application for a dwelling in a rural area.

**Published by Meath County Council.**

- **Sustainable Rural Housing Guidelines for Planning Authorities**

**Published by The Department of The Environment, Heritage and Local Government ( DoEHLG ) April 2005.**

- **An Introduction to the Architectural Heritage of County Meath**

**Published by The Department of The Environment & Local Government & Dúchas, The Heritage Service.**

- **A Lost Tradition. The Nature of Architecture In Ireland.**

**Niall McCullough + Valerie Mulvin. Published by Gandon Editions Dublin.**

- **Irish Countryside Buildings. Everyday Architecture In The Rural Landscape.**

**Patrick and Maura Shaffrey. Published by The O'Brien Press Dublin.**

- **Classic Irish Houses Of The Middle Size.**

**Maurice Craig. Published by Ashfield Press.**



1. Shay Scanlon Architects. [www.ssarch.ie](http://www.ssarch.ie) Brendan Landy Photography

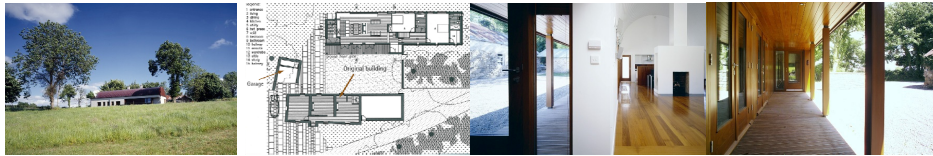

2. Max O'Flaherty , Aughey O' Flaherty Architects. [www.aof.e](http://www.aof.e)

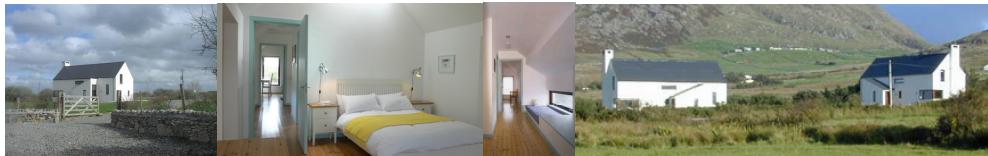

3. Paul Keogh, Paul Keogh Architects. [www.pka.ie](http://www.pka.ie).



4. Gary Mongey, Box Architecture. [www.box.ie](http://www.box.ie) Paul Tierney Photography <http://paultierney.com>

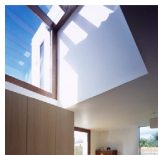

4a. Gary Mongey, Box Urban. [www.box.ie](http://www.box.ie)

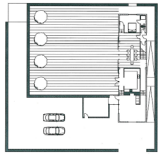

5. Eamon McCarney , Taylor Architects. [Info@taylorarchitects.ie](mailto:Info@taylorarchitects.ie).

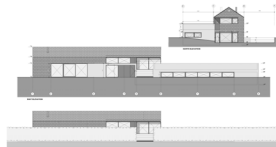

6. Dermot Boyd, Boyd Cody Architects, [www.bodycodtarch.com](http://www.bodycodtarch.com)



7. James Halpin, James Halpin Architects. [jharch@eircom.net](mailto:jharch@eircom.net) Barbara Egan Photography



8. Patrick Gilson Architect